

HIGH PERFORMANCE HORIZONTAL TURNING CENTER

PUMA 2100·2600·3100

PUMA 2100/L/M/LM/MS/LMS

PUMA 2100Y/LY/SY/LSY

PUMA 2600/L/M/LM/MS/LMS/LMSB

PUMA 2600/Y/LY/SY/LSY/LSYB

PUMA 2600|500/M|500/B/LB/MB/LMB/SB/MSB

PUMA 3100/L/XL/UL/M/LM/XLM/ULM

PUMA 3100/Y/SY/LY/LSY/XLY/XLYB/ULY/ULYB



PUMA 2100 · 2600 · 3100

PUMA 2100/2600/3100 series has been developed to create full line up of high level 12" to 15" size with model variations from 2 axis to Y axis and sub spindle.

CONTENTS

Product Overview

Basic Information

- 04 Basic Structure
- 05 Machining Area
- 06 Spindle
- 07 Turret
- 08 Tailstock

Detailed Information

- 09 Standard / Optional Specifications
- 11 Peripheral Equipment
- 12 DN SOLUTIONS FANUC i PLUS
- 14 SIEMENS S828D
- 15 Power | Torque
- 18 External Dimensions
- 20 Tooling System
- 26 Tool Interference Diagram
- 32 Machine Specification

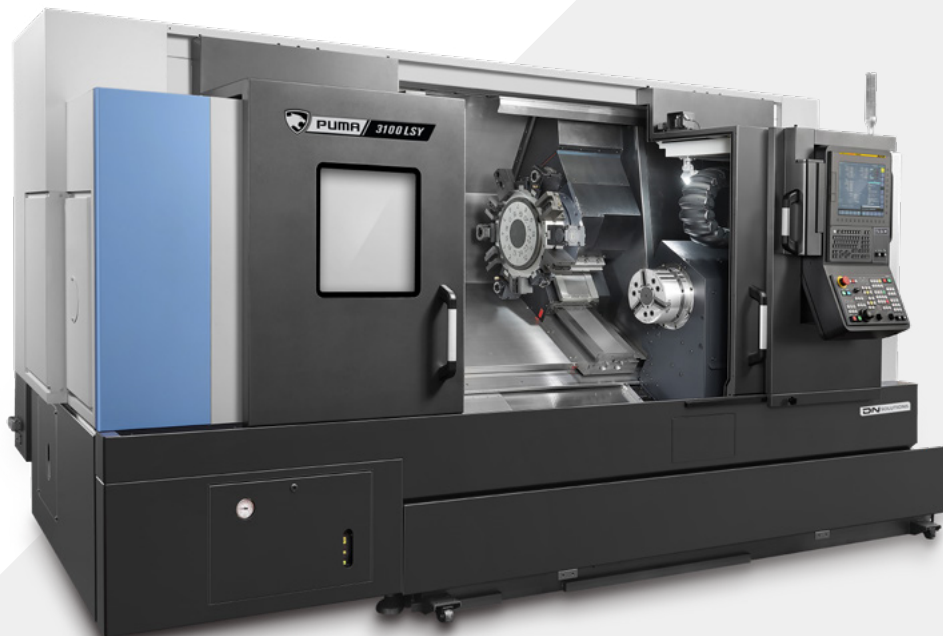

HIGH PERFORMANCE

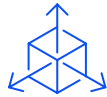

These DN Solutions machines offer a high level of machining capability to provide optimum productivity for the customer.

WIDE VARIATION



A wide variety of machine specifications from 2-axis models to turning centers with sub spindles is available to meet your production requirements.

EASY OPERATION



User-friendly operation panel configurations, EZ Guide i and EZ Work can make easy and comfortable to use various features of the product.

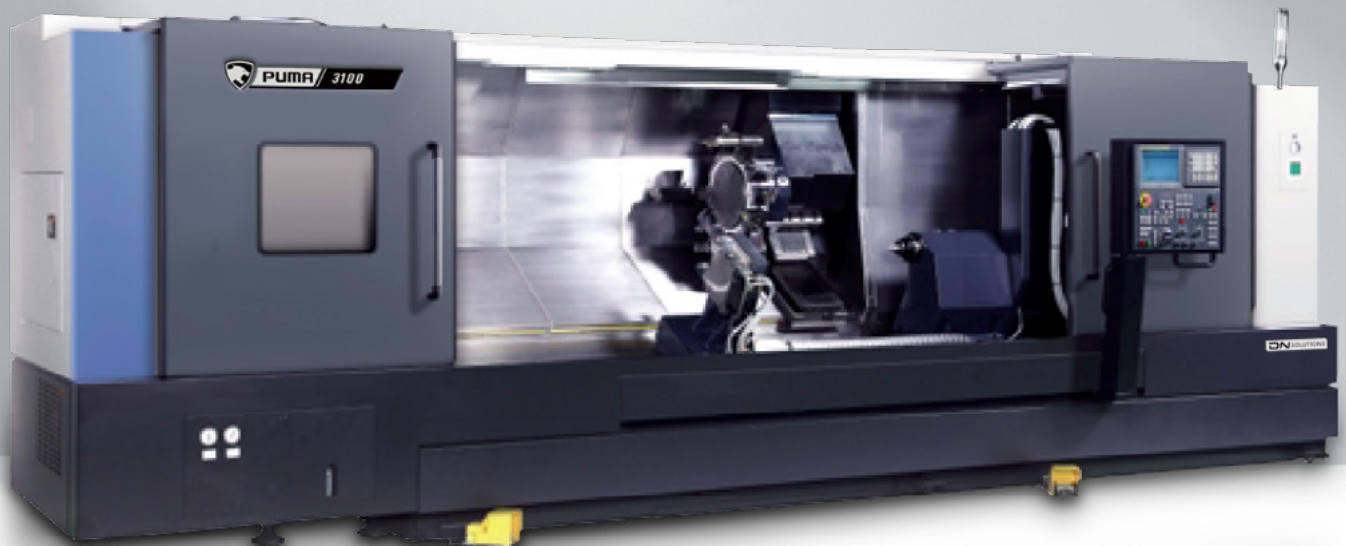

BASIC STRUCTURE

Box guideways are applied to all axes to prevent vibration, secure dynamic rigidity, and ensure powerful and precise machining.

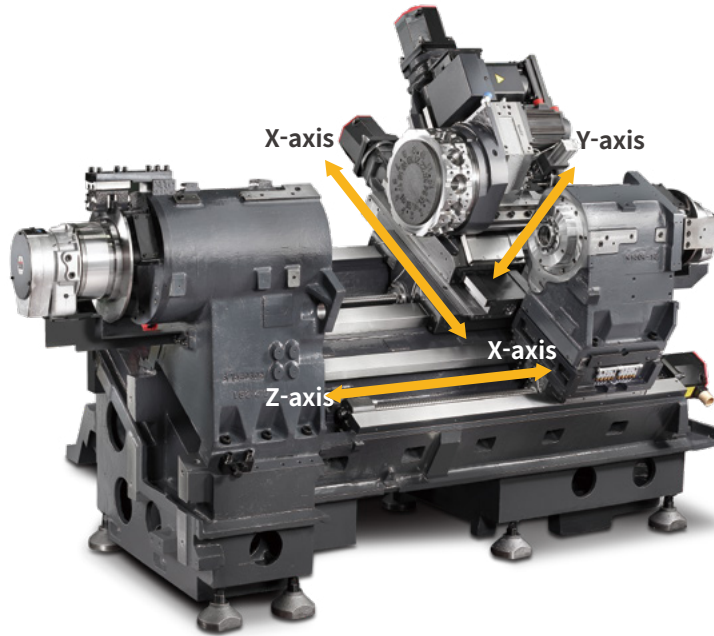

Unit : mm (inch)

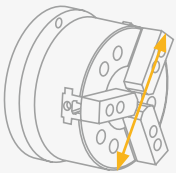

Ø 210 mm
(Ø 8.3 inch)

	520 (20.5)	760 (29.9)	1280 (50.4)	2125 (83.7)	3125 (123.0)
PUMA 2100				2A / M / MS / Y / SY	
PUMA 2100L				2A / M / MS / Y / SY	

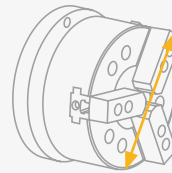

Ø 315 mm
(Ø 12.4 inch)

	520 (20.5)	760 (29.9)	1280 (50.4)	2125 (83.7)	3125 (123.0)
PUMA 2600B				2A / M / S / MS / Y / SY	
PUMA 2600LB				2A / M / Y	
PUMA 3100				2A / M / Y / SY	
PUMA 3100L				2A / M / Y / SY	
PUMA 3100XL				2A / M / Y	
PUMA 3100UL				2A / M / Y	

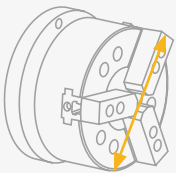

Ø 255 mm
(Ø 10 inch)

	520 (20.5)	760 (29.9)	1280 (50.4)	2125 (83.7)	3125 (123.0)
PUMA 2600/500				2A / M	
PUMA 2600				2A / M / MS / Y / SY	
PUMA 2600L				2A / M / MS / Y / SY	

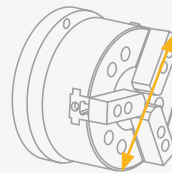

Ø 380 mm
(Ø 15 inch)

	520 (20.5)	760 (29.9)	1280 (50.4)	2125 (83.7)	3125 (123.0)
PUMA 3100XLB				Y	
PUMA 3100ULB				Y	

MACHINING AREA

These machines provide outstanding performance from general machining to large & long workpiece machining.

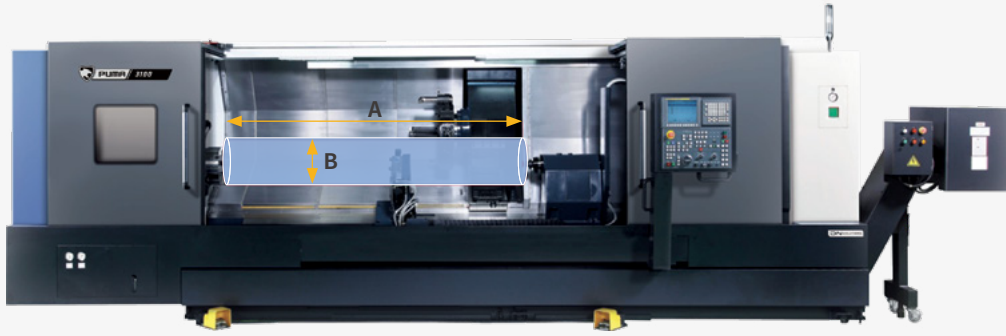

Unit : mm (inch)

Model	Max. turning length (A)	Max. turning dia. (B)
PUMA 2100	545 (21.4)	481 (18.9)
PUMA 2100M / MS / Y / SY	520 (20.5)	406 (16.0)
PUMA 2100L	785 (30.9)	481 (18.9)
PUMA 2100LM / LMS / LY / LSY	760 (29.9)	406 (16.0)
PUMA 2600	790 (31.1)	481 (18.9)
PUMA 2600M / MS / Y / SY	760 (29.9)	376 (14.8)
PUMA 2600L	1310 (51.6)	481 (18.9)
PUMA 2600LM / LMS / LY / LSY	1280 (50.4)	376 (14.8)
PUMA 2600/500	550 (21.7)	481 (18.9)
PUMA 2600M/500	520 (20.5)	376 (14.8)
PUMA 2600B / SB	755 (29.7)	481 (18.9)
PUMA 2600LB	1275 (50.2)	481 (18.9)
PUMA 2600MB / MSB	725 (28.5)	376 (14.8)
PUMA 2600LMB / LYB	1245 (49.0)	376 (14.8)
PUMA 3100	790 (31.1)	525 (20.7)
PUMA 3100M / Y / SY	765 (30.1)	420 (16.5)
PUMA 3100L	1310 (51.6)	525 (20.7)
PUMA 3100LM / LY / LSY	1285 (50.6)	420 (16.5)
PUMA 3100XL	2150 (84.7)	525 (20.7)
PUMA 3100XLM / XLY / XLYB	2125 (83.7)	420 (16.5)
PUMA 3100UL	3150 (124.0)	525 (20.7)
PUMA 3100ULM / ULY / ULYB	3125 (123.0)	420 (16.5)

High performance Y axis complex machining

Free operation in all directions of the rotary milling tool using Y axis control perform a variety of complex shape machining easily with high accuracy.

PUMA 2100/2600

105 (±52.5) mm
(4.1 (±2.1) inch)

PUMA 3100

130 (±65) mm
(5.1 (±2.6) inch)

Groove nish cutting using the Y-axis

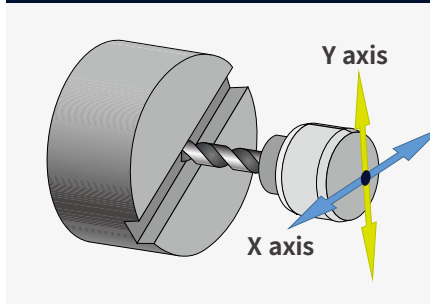

Multi-face cutting

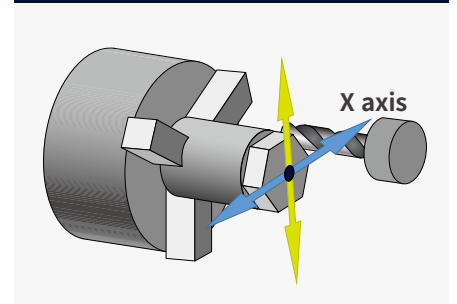

Milling in an eccentric position

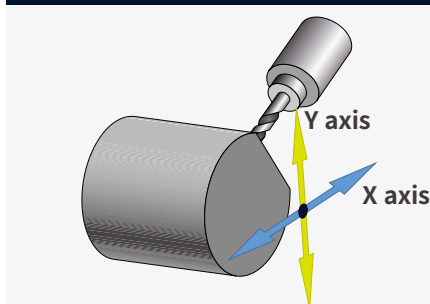

Y & X axes circular interpolation

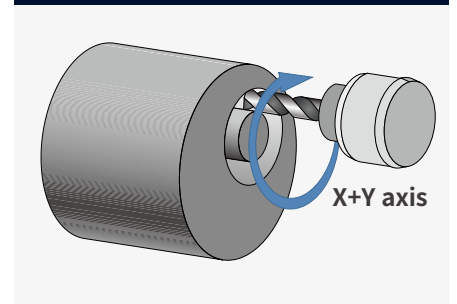

SPINDLE

Applying superior spindle motor & increase rigidity of headstock, to achieve stable performance during heavy & high speed machining.

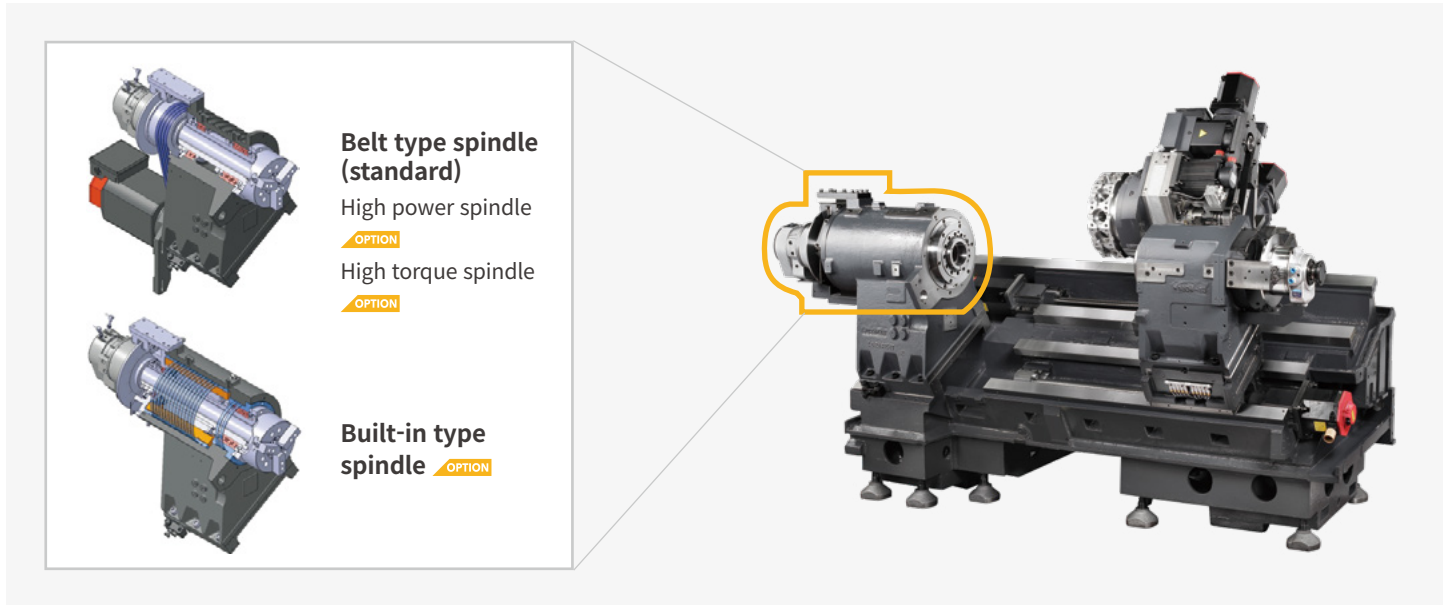

Model	Type	Max. speed r/min	Max. power kW (Hp)	Max. torque N.m (ft-lbs)
PUMA 2100	Belt	4500	25 (33.5)	247 (182.3)
PUMA 2600	Belt	3500	30 (40.2)	327 (241.3)
PUMA2600/500	Belt	3500	25 (33.5)	322 (237.6)
PUMA 2600B	Belt	2800	26 (34.9)	1123 (829)
PUMA 3100/L	Belt	2800	26 (34.9)	1123 (829)
	High torque*	2800	35 (46.9)	1613 (1190.4)
PUMA 3100XL/UL	Built-in	3000	30 (40)	1203 (888)
	Belt	2800	26 (34.9)	1123 (829)
	High power	2800	30 (40)	1150 (848.7)
	High torque*	2800	35 (46.9)	1613 (1190.4)
PUMA 3100XLYB/ULYB	Built-in	3000	30 (40)	1203 (888)
	Belt	2000	30 (40)	1611 (1188.9)

Sub spindle

Sub spindle function allow rear side cutting in a single setup.

Model	Type	Max. speed r/min	Max. power kW (Hp)	Max. torque N.m (ft-lbs)
PUMA 2100/ PUMA 2600 / PUMA 2600B	Belt	4500	7.5 (10)	85 (61)
PUMA 3100	Built-in	4000	30 (40)	600 (442.8)

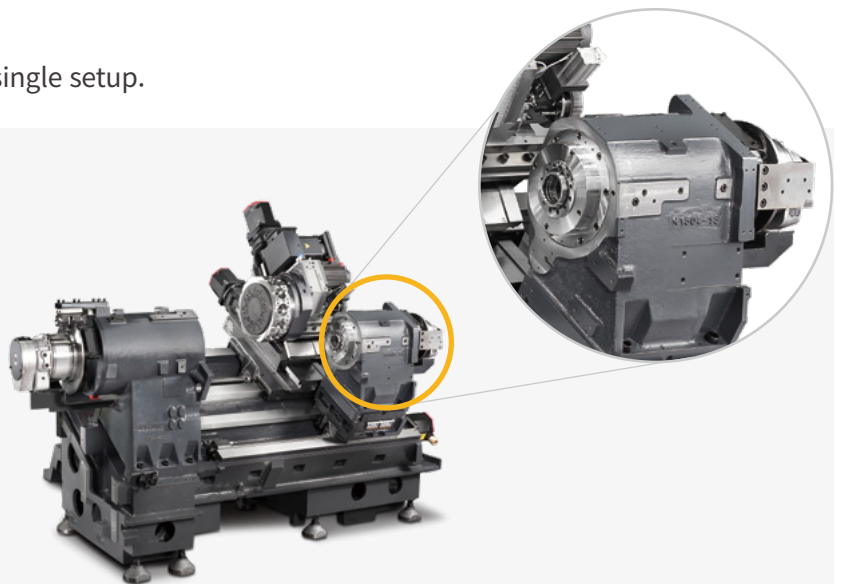

TURRET

Turret rotation is controlled by servo motor for fast and reliable tool selection. DN Solutions's unique BMT turret design is used on M and Y specification models to boost heavy duty milling performance.

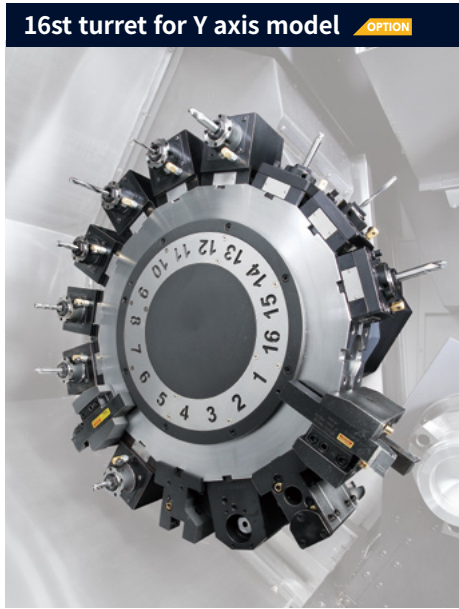
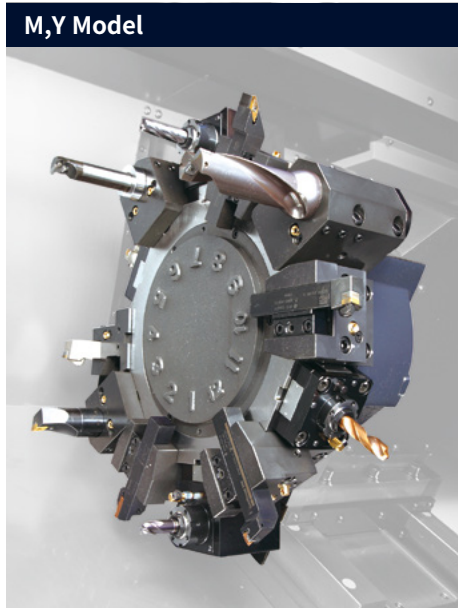
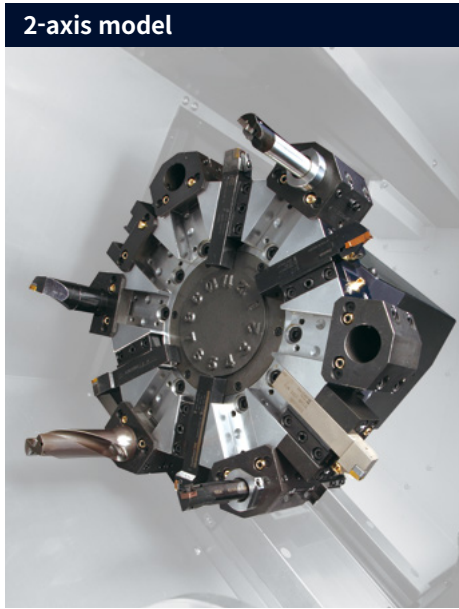

No. of tool stations

PUMA 2100 / 2600

12 st

PUMA 3100

10 {12 OPTION} st

No. of tool stations

PUMA 2100 : BMT 55P / BMT 65P

PUMA 2600 / 3100 : BMT 65P

12 st

Position index

12 {24 OPTION} index

No. of tool stations

PUMA 2100 / 2600 : BMT 55P

16 st

Position index

16 index

Available Model

- PUMA 2100Y / LY / SY / LSY
- PUMA 2600Y / LY / SY / LSY

Rotary tool power-torque diagram

Max. spindle speed : 5000 r/min
 Max. spindle power : 5.5 kW (7 Hp)

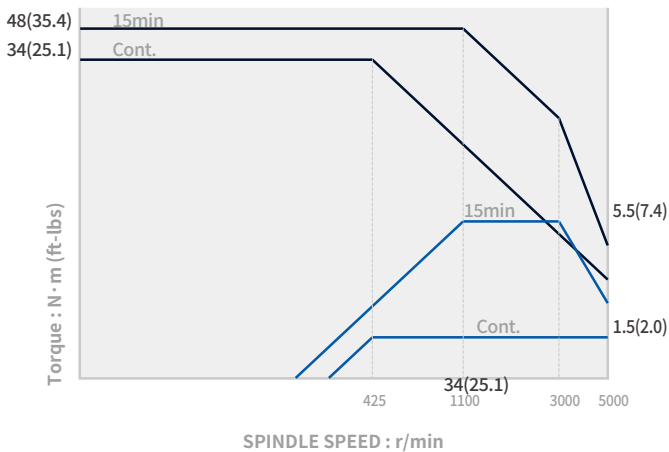

Rotary tool power-torque diagram OPTION

Max. spindle speed : 5000 r/min
 Max. spindle power : 7.5 kW (10 Hp)

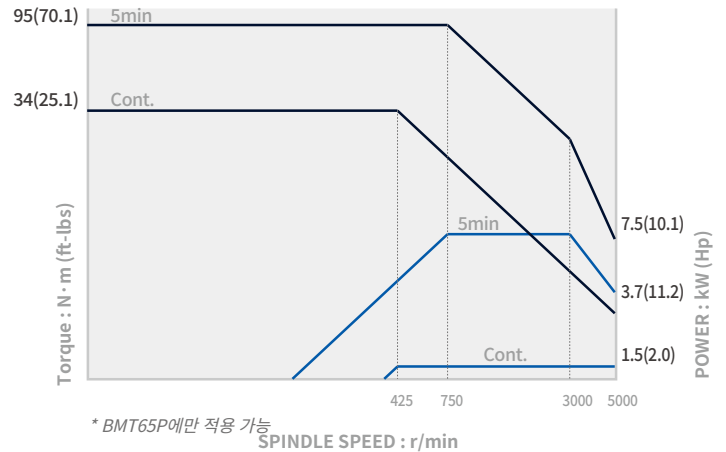

* BMT65P에만 적용 가능

TAILSTOCK

High rigidity hydraulic tailstock is rigidly clamped to the bed slide way to provide stable support for long workpieces.

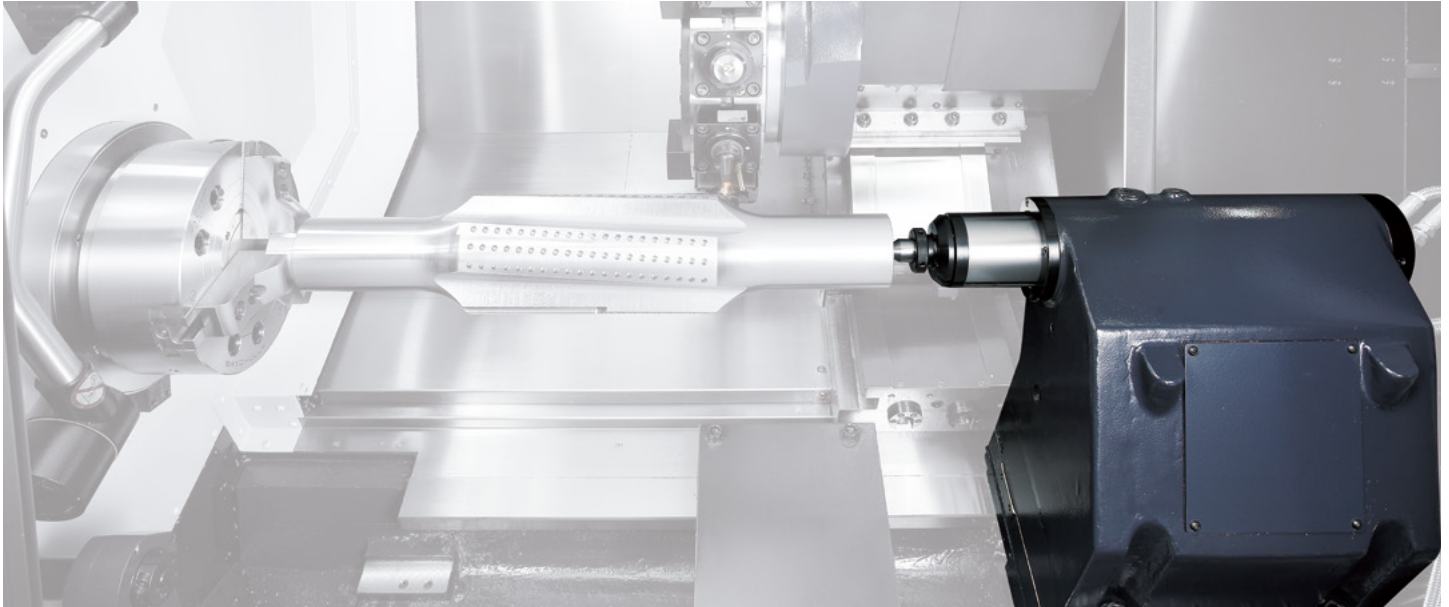

Tailstock type

- Manual
- Programmable
- Servo driven

Tailstock EZ function

In programmable tail stock, the Z-axis position of tail stock is recorded automatically as the clamped position of tail stock.



Tailstock type		PUMA 2100 / L series	PUMA 2600 / L series PUMA 3100 / L series	PUMA 3100XL / UL series
 <p>Manual</p>	Live center MT4	Standard	Not available	Not available
	Built-in center MT3	Option		
	Live center MT5	Not available	Standard	
	Built-in center MT4		Option	
 <p>Programmable</p>	Live center MT4	Option	Not available	Not available
	Built-in center MT3			
	Live center MT5	Not available	Option	
	Built-in center MT4			
	Built-in center MT5		Not available	
 <p>Servo driven</p>	Live center MT4	Option	Not available	Not available
	Built-in center MT3			
	Live center MT5	Not available	Option	
	Built-in center MT4			

STANDARD | OPTIONAL SPECIFICATIONS

Diverse optional features are available for customer-specific work applications.

Description	PUMA 2100(L) / 2600(L)					PUMA 3100 Std./L			PUMA 3100 XL/UL			
	2-axis Std.	M	MS	Y	SY	2-axis Std.	M	Y	2-axis Std.	M	Y/YB	
Special chucks	△	△	△	△	△	△	△	△	△	△	△	
Soft jaws	●	●	●	●	●	●	●	●	●	●	●	
Dual pressure chucking	○	○	○	○	○	○	○	○	○	○	○	
Hydraulic chuck pressure switch	○	○	○	○	○	○	○	○	○	○	○	
Chuck clamp confirmation	●	●	●	●	●	●	●	●	●	●	●	
Tail stock center : Live center	●	●	x	●	x	●	●	●	x	x	x	
Tail stock center : Dead center	○	○	x	○	x	○	○	○	●	●	●	
Tail stock : Manual	●	●	x	●	x	●	●	●	x	x	x	
Tail stock : Programmable	○	○	x	○	x	○	○	○	●	●	●	
Tail stock : Servo driven	○	○	x	○	x	○	○	○	x	x	x	
Automatic quill advance & retract	○	○	x	○	x	○	○	○	○	○	○	
Rotary tool holder	x	●	●	●	●	x	●	●	x	●	●	
Tool setter : Manual	○	○	○	○	○	○	○	○	○	○	○	
Tool setter : Automatic_electric	○	○	○	○	○	○	○	○	○	○	○	
Auto workpiece measurement	○	○	○	○	○	○	○	○	○	○	○	
Linear scale (X-axis)	○	○	○	○	○	○	○	○	○	○	○	
Linear scale (Z-axis)	○	○	○	○	○	○	○	○	○	○	○	
Linear scale (Y-axis)	x	x	x	○	○	x	x	○	x	x	○	
Feedback system : Absolute position encoder	●	●	●	●	●	●	●	●	●	●	●	
Bar feeder interface	○	○	○	○	○	○	○	○	○	○	○	
Bar puller	△	△	△	△	△	△	△	△	x	x	x	
Workpiece ejector	x	x	○	x	○	x	x	x	x	x	x	
Parts catcher with box	○	○	○	○	○	△	△	△	x	x	x	
Parts catcher with conveyor	○	○	○	○	○	△	△	△	x	x	x	
Workpiece cut off confirmation	x	x	○	x	○	x	x	x	x	x	x	
Automatic front door : with safety device	○	○	○	○	○	○	○	○	○	○	○	
Chip conveyor type : Right side	○	○	○	○	○	○	○	○	○	○	○	
Chip conveyor type : Rear side *1	○	○	○	○	○	○	○	○	x	x	x	
Chip bucket	○	○	○	○	○	○	○	○	○	○	○	
TSC for main / left spindle	○	○	○	○	○	○	○	○	○	○	○	
Oil skimmer	○	○	○	○	○	○	○	○	○	○	○	
Coolant level switch : Sensing level - Low	○	○	○	○	○	○	○	○	○	○	○	
Water soluble Coolant Chiller**	○	○	○	○	○	○	○	○	○	○	○	
Oil mist collector	○	○	○	○	○	○	○	○	○	○	○	
Coolant blower	○	○	○	○	○	○	○	○	○	○	○	
Air blower	○	○	○	○	○	○	○	○	○	○	○	
Air gun	○	○	○	○	○	○	○	○	○	○	○	
Signal tower (yellow, red, green)	○	○	○	○	○	○	○	○	○	○	○	
Gantry loader	△	△	△	△	△	△	△	△	△	△	△	
V-stand for shaft workpiece	○	○	x	○	x	○	○	○	x	x	x	
Quick change tooling(CAPTO)	○	○	○	○	○	○	○	○	○	○	○	
Sketch-turn S/W	○	○	○	○	○	○	○	○	○	○	○	
Customized Special Option	MAIN SPINDLE TSC	○	○	○	SD17568-P2100 II-TSC (PUMA 2100Y II /LY II), SD18582-P2600 II-TSC (PUMA 2600Y II /LY II)	SD17568-P2100 II-TSC (PUMA 2100SY II/LSY II), SD18582-P2600 II-TSC (PUMA 2600SY II/LSY II)	○	○	○	○	○	○
	4JAW MAIN CHUCK	MHF208 (PUMA 2100/L/LS), MHF210 (PUMA 2600/L/LS)	MHF208 (PUMA 2100M/LM) / MHF210 (PUMA 2600M/LM)	MHF208 (PUMA 2100MS/LMS) / MHF210 (PUMA 2600MS/LMS/MSB)	MHF208 (PUMA 2100Y/LY/Y II /LY II) / MHF210 (PUMA 2600Y/LY/Y II/LY II)	MHF208 (PUMA 2100SY/LSY/SY II/LSY II) / MHF210 (PUMA 2600SY/LSY/LSYB/SY II/LSY II)	○	○	○	○	○	○
	WORKPIECE MEASUREMENT	OLP40 (PUMA 2100/L/LS, PUMA 2600/L/LS/B/LB/SB)	OLP40 (PUMA 2100M/LM, PUMA 2600M/LM/MB/LMB/M-500)	OLP40 (PUMA 2100MS/LMS, PUMA 2600MS/LMS/MSB)	OLP40 (PUMA 2100Y/LY/Y II/LY II, PUMA 2600Y/LY/Y II/LY II/YB II/LYB II)	OLP40 (PUMA 2100SY/LSY/SY II/LSY II /SYB II/LSYB II, PUMA 2600SY/LSY/LSYB/SY II/LSY II)	OLP40 (PUMA 3100/L/XL/UL)	OLP40 (PUMA 3100M/LM/XLM/ULM)	OLP40 (PUMA 3100Y/LY/XLY/ULY)	○	○	OLP40 (PUMA 3100XLYB/ULYB)
	BEAM SENSOR TYPE SAFETY SWITCH	KEYENCE (PUMA 2600B/LB/SB)	KEYENCE (PUMA 2600MB/LMB)	KEYENCE (PUMA 2600MSB)	○	○	○	○	○	○	○	○

* Please contact your DN Solutions representative for detailed machine information .

● Standard ○ Optional x N/A

* When using a semi-synthetic type or synthetic type, contact our sales representative or service center in advance.

*1 : PUMA 2100/L, PUMA 2600, PUMA 3100 only * Please contact DN Solutions to select detailed steady rest specifications.

** Technical consultation is mandatory for the chilling of non-water soluble coolant.

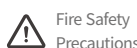

There is a high risk of fire when using non-water-soluble cutting fluids, processing flammable materials, neglecting the controlled and careful use of coolants and modifying the machine without the consent of the manufacturer. Always check the SAFETY GUIDELINES carefully before using the machine.

STANDARD | OPTIONAL SPECIFICATIONS

Diverse optional features are available for customer-specific work applications.

Steady rest

Steady Rest		PUMA 2100		PUMA 2600		PUMA 3100	
		Std.	L	Std.	L	Std./L	XL/UL
Type	Programmable	○	○	○	○	○	○
	Servo driven *1	x	x	x	x	x	○
Size	SLU-1	○	○	○	○	x	x
	SLU-2	○	○	○	○	○	○
	SLU-B3.1	x	○	○	○	x	x
	SLU-3.1	x	x	x	x	○	○
	SLU-3.2	x	x	x	x	x	○
	SLU-4	x	x	x	x	x	○ ²
	SLU-B4	x	x	x	x	x	○
	STA-1	○	○	○	○	x	x
	STA-2	○	○	○	○	○	○
	STA-3.1	x	x	x	x	○	○
	STA-3.2	x	x	x	x	x	○
	STA-4	x	x	x	x	x	○
	AX-1	○	○	○	○	○	○
	AX-2	○	○	○	○	○	○
	AX-3	○	○	○	○	○	○
	AX-4	○	○	○	○	○	○
	AX-5	○ ³	○ ³	○ ³	○ ³	○ ³	○
	AX-6	x	x	x	x	x	○ ³
	AX-7	x	x	x	x	x	○ ³

● Standard ○ Optional x N/A

High pressure coolant

Model		PUMA 2100 / 2600 / 3100	
		60Hz	50Hz
Standard	1.5 bar	0.4kW x 0.15 Mpa x 60L/min	0.4kW x 0.12Mpa X 40L/min
	4.5bar	0.75kW x 0.45 Mpa x 30L/min	0.75kW x 0.3 Mpa x 30L/min
Optional	7 bar	1.1kW x 0.7 Mpa x 30L/min	1.1kW x 0.5 Mpa x 30L/min
	10 bar*	1.1kW x 1.0 Mpa x 20L/min	1.1kW x 0.7 Mpa x 20L/min
	14.5 bar*	2.2W x 1.45 Mpa x 35L/min	2.2kW x 1.0 Mpa x 35L/min
Special Optional	20 bar*	2.2kW x 2.0 Mpa x 30L/min	2.2kW x 2.0 Mpa x 30L/min
	70 bar*	7.5kW x 7.0 Mpa x 29L/min	7.5kW x 7.0 Mpa x 20L/min

* Please contact your DN Solutions representative for detailed machine information.

* When using a semi-synthetic type or synthetic type, contact our sales representative or service center in advance.

* 1 : Rack & Pinion type.

* 2 : SLU-4 is not available in servo driven type.

* 3 : E-type is unavailable

* Recommend using coolant chiller



Fire Safety
Precautions

There is a high risk of fire when using non-water-soluble cutting fluids, processing flammable materials, neglecting the controlled and careful use of coolants and modifying the machine without the consent of the manufacturer. Always check the SAFETY GUIDELINES carefully before using the machine.

PERIPHERAL EQUIPMENTS

Oil skimmer OPTION

The oil skimmer keeps coolant and lubricant isolated from each other for extending lifecycle of coolant.

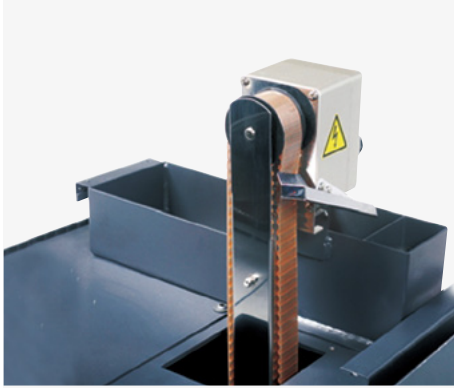

Tool setter OPTION

The tool setter facilitates setting of tools, and fast and precise length compensation of abraded tool.



Part catcher OPTION

The part catcher automatically accepts parts completed of machining, and ejects them out of the system.



Coolant chiller OPTION

Coolant chiller is highly recommended to prevent temperature rise and minimize thermal deformation, when using a water-insoluble coolant or high-pressure coolant system of which the power is over 1.5 kw.

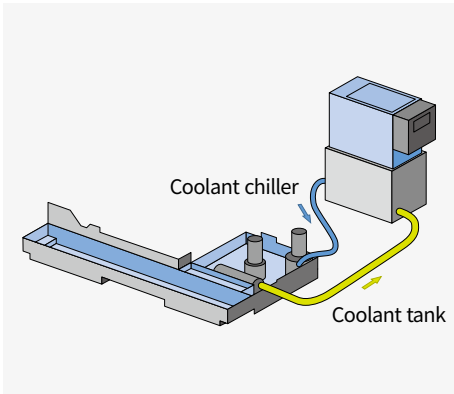

Quick change CAPTO OPTION

The Quick Change Tool system simplifies tool change operation. Recommended for users who need to change tools frequently or reduce the set-up time.



Mist collector OPTION

The mist collector absorbs airborne oil vapor and fine dusts in the system to improve working environment.



Collet chuck OPTION

The collet chuck is ideal for loading workpiece of small diameter and light weight.

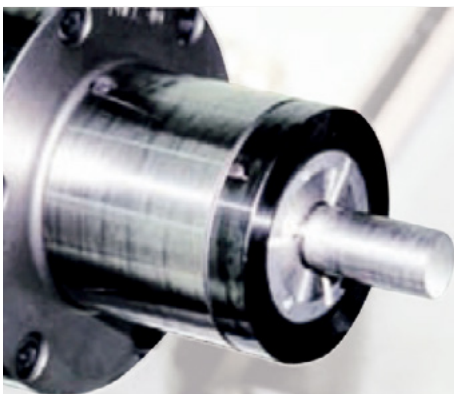

Coolant blower OPTION



Signal tower OPTION



FANUC i PLUS

DN Solutions Fanuc i Plus maximizes customer productivity and convenience.

15" Screen + New OP

DN Solutions Fanuc i Plus' operation panel enhances operating convenience by incorporating common-design buttons and layout. It features a Qwerty keyboard for fast and easy data input and operation.

DN Solutions Fanuc i Plus

- 15-inch color display
- Intuitive and user-friendly design

USB and PCMCIA card QWERTY keyboard

- EZ-Guide i standard
- Ergonomic operator panel
- 2MB Memory
- Hot keys



iHMI touchscreen OPTION

iHMI provides an intuitive interface that uses a touchscreen for quick and easy operation.

Range of applications

Providing various applications related to planning, machining, improvement and utility, for customer convenience.



SKETCH-TURN OPTION

DN Solutions Conversational programming software for PC

- Easy to learn for beginners
- Time savings in programming
- Reduce processing cycle time



NUMERIC CONTROL SPECIFICATIONS



Description	Item	Specifications	2-Axis	M	S	MS	Y	SY
			DN Solutions-Fanuc i (F0i-F Plus)					
Controlled axis	Controlled axes		2 (X,Z)	3 (X,Z,C)	3 (X,Z,B)	4 (X,Z,C,B)	4 (X,Z,C,Y)	6 (X,Z,C1,Y,C2,B)
	Simultaneously controlled axes		2 axes	3 axes	3 axes	4 axes	4 axes	4 axes
Operation	DNC operation	Included in RS232C interface.	●	●	●	●	●	●
	DNC operation with memory card		●	●	●	●	●	●
Feed function	AI contour control I		○	○	○	○	●	●
	AI contour control II		○	○	○	○	○	○
Program input	Workpiece coordinate system	G52 - G59	●	●	●	●	●	●
Operation Guidance Function	EZ Guide i (Conversational Programming Solution)	Note *1) Only with 15" LCD standard	● *1)	● *1)	● *1)	● *1)	● *1)	● *1)
	iHMI with Machining Cycle	Note *2) Only with 15" Touch LCD standard	○ *2)	○ *2)	○ *2)	○ *2)	○ *2)	○ *2)
	EZ WORK		●	●	●	●	●	●
Setting and display	CNC screen dual display function		●	●	●	●	●	●
Data input/output	Fast data server		○	○	○	○	○	○
	Large capacity memory_2GB	Note *3) Available Option only with 15" Touch LCD (iHMI Only)	○ *3)	○ *3)	○ *3)	○ *3)	○ *3)	○ *3)
	Memory card input/output		●	●	●	●	●	●
	USB memory input/output		●	●	●	●	●	●
Interface function	Embedded Ethernet		●	●	●	●	●	●
	Fast Ethernet		○	○	○	○	○	○
Others	Display unit	15" color LCD	●	●	●	●	●	●
		15" color LCD with Touch Panel	○	○	○	○	○	○

CONVENIENT OPERATION

EZ-Guide i

Using the DN Solutions EZ-Guide i, users can create a cutting program for any desired shape, including patterns, by entering just the dimensions.

Example programming : Cutting shape

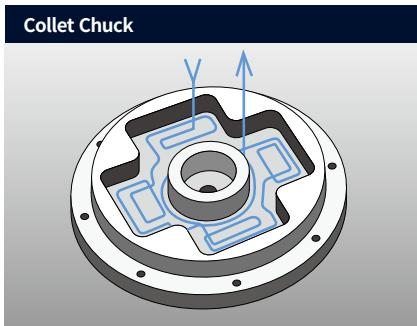
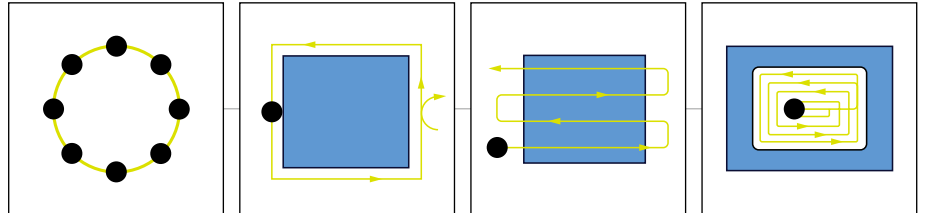

```

Automatic creation of cutting program

O7000 (SAMPLE PROGRAM) ;
...
M3 S1500 ;
G0 X50. Y125. ;
G0 Z30. ;
G1040 T0.5 J3. H0.2 K0.5 ... ;
G1020 H120. V50. U37. W68. ... ;
G0 Z80. ;
M5 ;

```

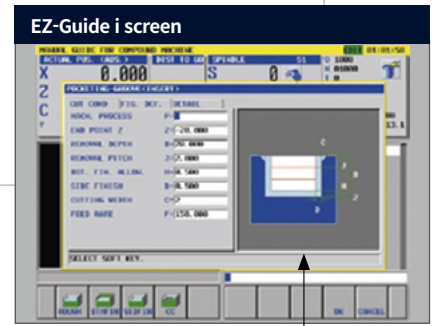

A cutting program is automatically created with the entered values.

Enter the dimensions of the shape

EZ Work

DN Solutions's EZ work supports the user with functions relating to tool data, error diagnostics, set up and machine monitoring.

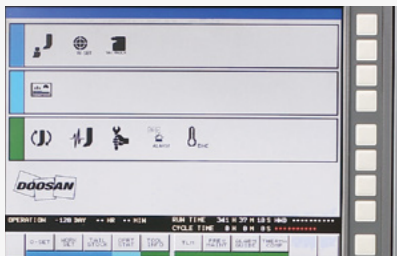

Select menu screen

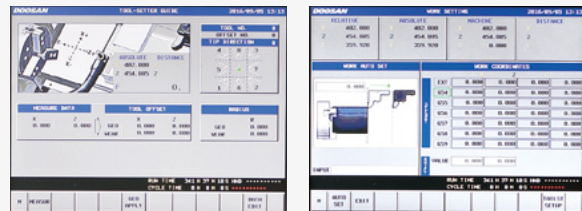

Convenient set up for peripheral equipment

Helps tool setter guide, work setting, tailstock setting, and other measurement and parameter control to reduce setting-up time and facilitates operation.

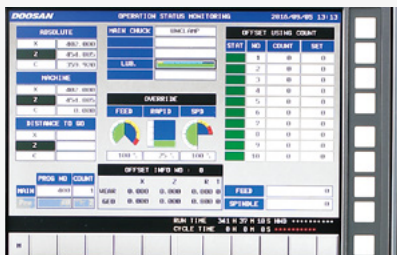

Screen for monitoring the machine and operating conditions

The screen provides a complete view of machine operation information on the feed system position, offset, feedrate and spindle speed, tool life and count in an easy-to-view screen.



Management Convenience Screen

Helps to prepare tools and provides for visual information on alarms to reduce maintenance time.

CONVENIENT OPERATION

Siemens S828D



15.6 inch display + New OP

Siemens 828D' operation panel enhances operating convenience by incorporating common-design buttons and layout. It features a Qwerty keyboard for fast and easy data input and operation.

- 15.6 inch display
- USB (standard)
- QWERTY keyboard

Conversational convenient function

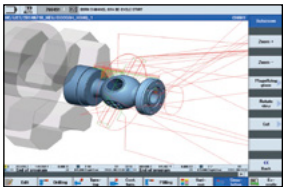

Cutting and operation support function
This function shows a cutting and tool path simulation in real-time.

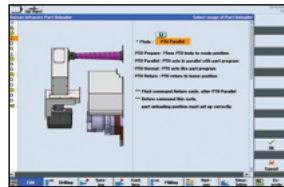

Shop-turn mode
[various]
↓
[attachments]

The automation elements (parts catcher, parts unloader etc.), can be easily controlled via interactive screens.

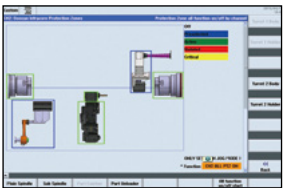

[Custom]
↓
[Protection zones]

Operation safety function
Protection Zone Synchronized Actions checks the interference between the turret and the spindle to prevent collisions caused by operator error.



[offset]
↓
[operating parameter]
↓
[TC service]

Maintenance and service convenience function
Maintenance and service of major equipment and peripheral devices, including the timer and parts counter settings can be easily undertaken.

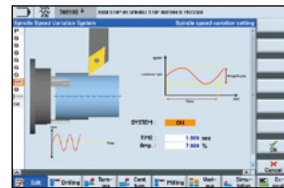

[various]
↓
[attachment]
↓
[DSSV]

Machining accuracy improvement
The NC controls spindle speed at an optimal level for precision threading and turning, making it possible to automatically improve surface roughness.

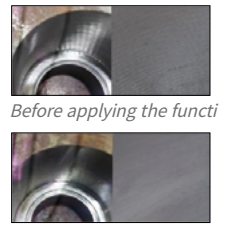

Before applying the function
After applying the function

NUMERIC CONTROL SPECIFICATIONS



Description	Item	Specifications	2-Axis S828D	M S828D	S S828D	MS S828D	Y S828D	SY S828D
Controlled axis	Controlled axes		X,Z,SP	X,Z,C,R	X,Z,C,C2,B	X,Z,C,R,C2,B	X,Z,C,R,Y	X,Z,C,R,C2,Y,B
	Simultaneously controlled axes		4 axes	4 axes	4 axes	4 axes	4 axes	4 axes
Data input/output	Memory card input/output		X	X	X	X	X	X
	USB memory input/output		●	●	●	●	●	●
Interface function	Ethernet (X130)		○	○	○	○	○	○
	On network drive (without EES option, Extcall)		●	●	●	●	●	●
Operation	On USB storage medium, e.g. memory stick (without EES option, Extcall)		●	●	●	●	●	●
	Workpiece coordinate system	G54 - G59, G507 - G599	●	●	●	●	●	●
Feed function	Advanced surface		X	X	X	X	X	X
	Top surface		X	X	X	X	X	X
	Look ahead number of block		100	100	100	100	100	100
Programming & Editing function	3D simulation, finished part		●	●	●	●	●	●
	Simultaneous recording		●	●	●	●	●	●
	DXF Reader for PC integrated in SINUMERIK Operate		○	○	○	○	○	○
Operation Guidance Function	Shopturn		●	●	●	●	●	●
	EZ Operation package		●	●	●	●	●	●
Setting and display	Operation via a VNC viewer		●	●	●	●	●	●
	Network		○	○	○	○	○	○
Others	Display unit	15.6" color display with touch screen	●	●	●	●	●	●
		CNC user memory 5MB	●	●	●	●	●	
		CNC user memory 100 MB	○	○	○	○	○	
		CNC user memory 6GB	X	X	X	X	X	
		CNC user memory 40GB (with PCU or IPC)	X	X	X	X	X	
		CNC user memory without limit(Execution from external storage devices)(EES / Using by USB or Network)	○	○	○	○	○	
		HMI user memory for CNC part program 6GB	X	X	X	X	X	

POWER | TORQUE

FANUC

PUMA 2100 series_Belt type

Max. spindle speed

4500 r/min

Max. motor power

22 kW

(29.5 Hp)

Max. motor torque

365 N·m

(269.4 ft-lbs)

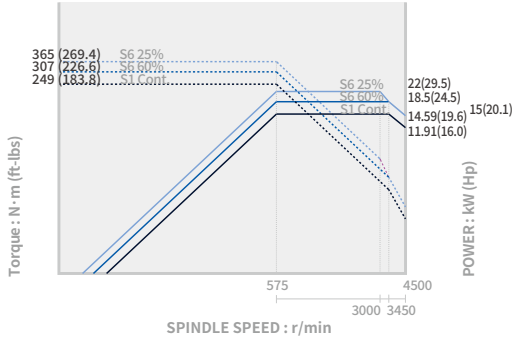

Max. spindle speed

4500 r/min

Max. motor power

18.5 kW

(25 Hp)

Max. motor torque

313 N·m

(231.0 ft-lbs)

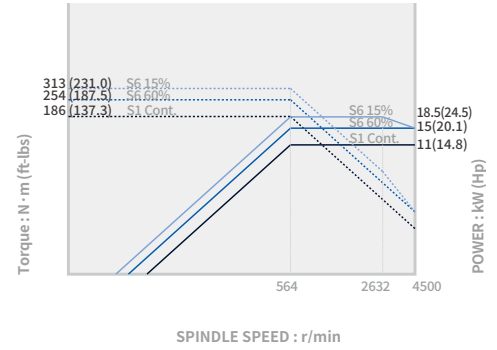

PUMA 2100 series_Belt type

Max. spindle speed

4500 r/min

Max. motor power

25 kW

(33.5 Hp)

Max. motor torque

247 N·m

(182.3 ft-lbs)

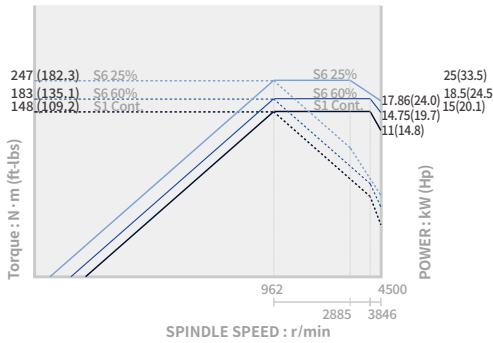

PUMA 2600 series_Belt type

Max. spindle speed

3500 r/min

Max. motor power

30 kW

(40.2 Hp)

Max. motor torque

327 N·m

(241.3 ft-lbs)

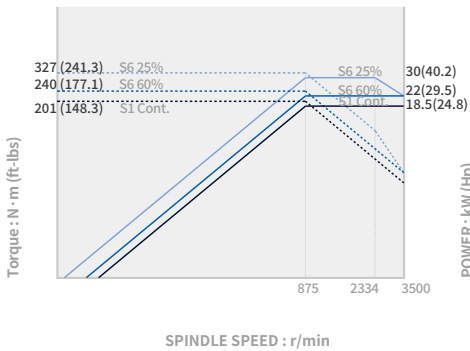

PUMA 2600 / 500, PUMA 2600M / 500_Belt type

Max. spindle speed

3500 r/min

Max. motor power

25 kW

(33.5 Hp)

Max. motor torque

322 N·m

(237.6 ft-lbs)

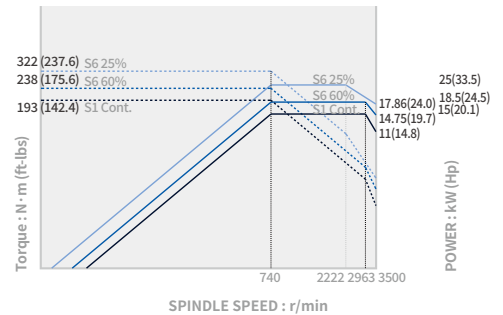

PUMA 2600, 2600/500, 2600M/500 series_Belt type

Max. spindle speed

3500 r/min

Max. motor power

22 kW

(29.5 Hp)

Max. motor torque

622 N·m

(459.0 ft-lbs)

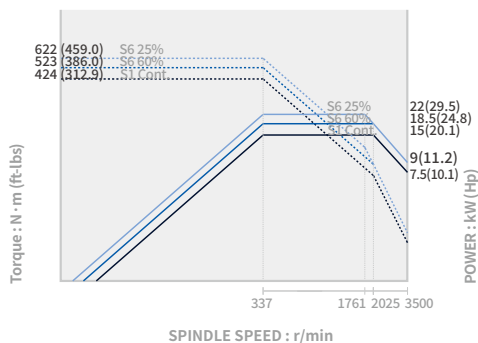

Max. spindle speed

3500 r/min

Max. motor power

26 kW

(34.9 Hp)

Max. motor torque

735 N·m

(542.4 ft-lbs)

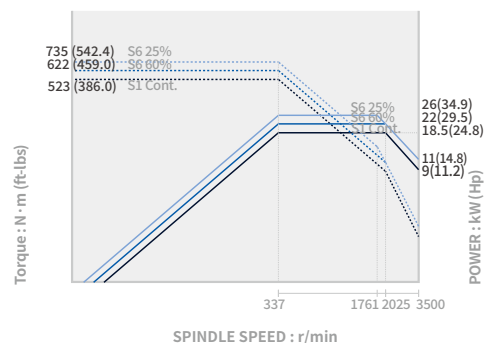

POWER | TORQUE

FANUC

PUMA 2600B / 3100 series_Belt type

Max. spindle speed
2800 r/min

Max. motor power
26 kW
(34.9 Hp)

Max. motor torque
1123 N·m
(828.8 ft-lbs)

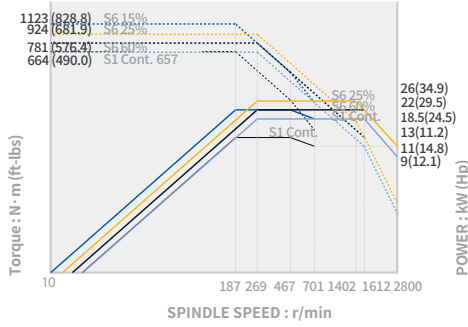

PUMA 2600B/LB, PUMA 3100/L/XL/UL only Belt type With Gear Box OPTION

Max. spindle speed
2800 r/min

Max. motor power
35 kW
(46.9 Hp)

Max. motor torque
1613 N·m
(1190.4 ft-lbs)

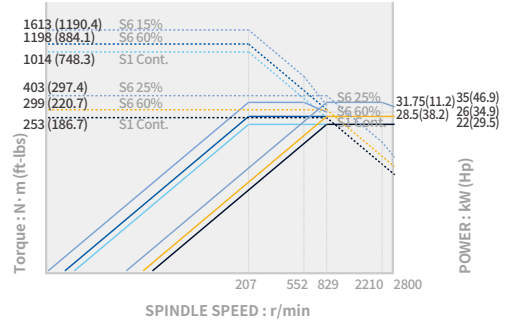

PUMA 3100 series_Built-in type

Max. spindle speed
3000 r/min

Max. motor power
30 kW
(40.2 Hp)

Max. motor torque
1024 N·m
(755.7 ft-lbs)

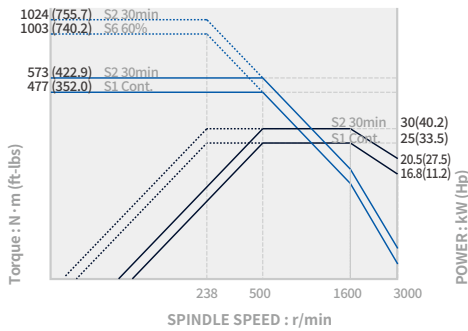

PUMA 3100 XL/UL_Belt type

Max. spindle speed
2800 r/min

Max. motor power
30 kW
(40.2 Hp)

Max. motor torque
1150 N·m
(848.7 ft-lbs)

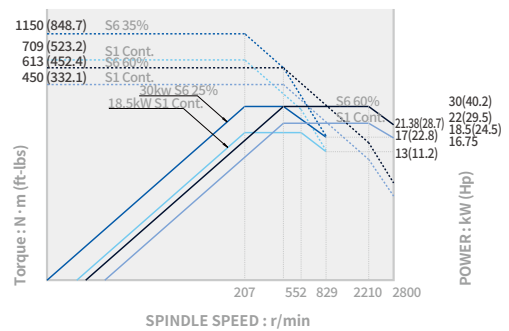

PUMA 3100 XLYB/ULYB_Belt type

Max. spindle speed
2000 r/min

Max. motor power
30 kW
(40.2 Hp)

Max. motor torque
1611 N·m
(1188.9 ft-lbs)

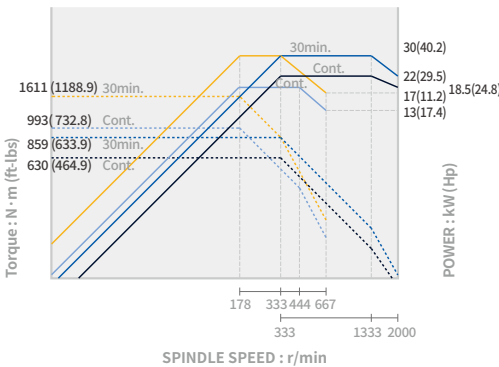

PUMA 2100/2600/2600B_Sub spindle_Belt type

Max. spindle speed
4500 r/min

Max. motor power
7.5 kW
(10.1 Hp)

Max. motor torque
85 N·m
(62.7 ft-lbs)

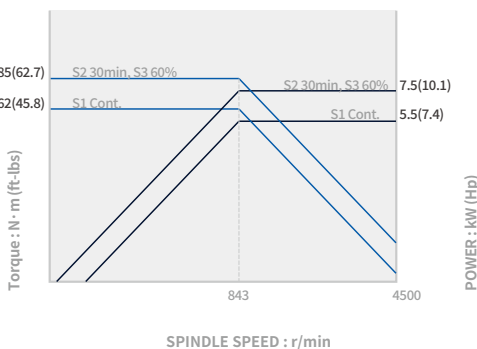

PUMA 3100_Sub spindle_Built-in type

Max. spindle speed
4000 r/min

Max. motor power
30 kW
(40.2 Hp)

Max. motor torque
600 N·m
(442.8 ft-lbs)

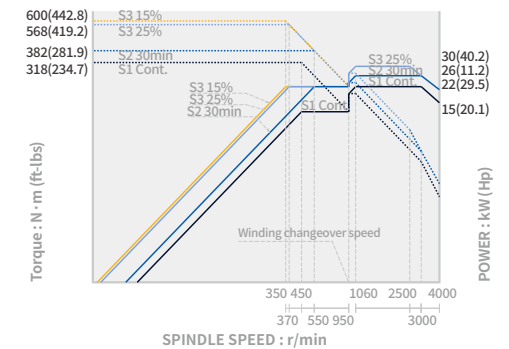

POWER | TORQUE

Rotary Tool Power (FANUC)

5.5 kW (7.4 Hp)

Max. spindle speed
5000 r/min

Max. motor power
5.5 kW
(7.4 Hp)

Max. motor torque
48 N·m
(35.4 ft-lbs)

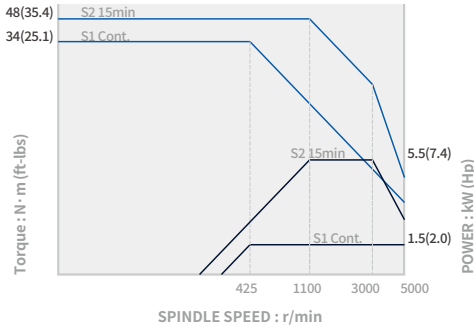

7.5 kW (10.1 Hp) OPTION

Max. spindle speed
5000 r/min

Max. motor power
7.5 kW
(10.1 Hp)

Max. motor torque
95 N·m
(70.1 ft-lbs)

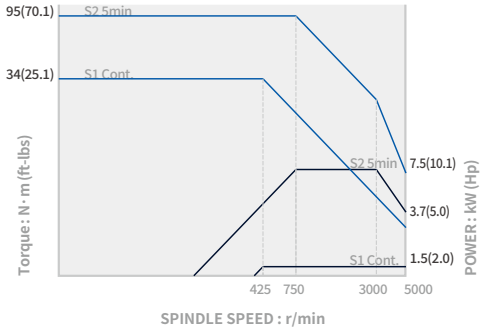

SIEMENS

PUMA 2100_Belt type

Max. spindle speed
4500 r/min

Max. motor power
26.4 kW
(35.4 Hp)

Max. motor torque
294 N·m
(217.0 ft-lbs)

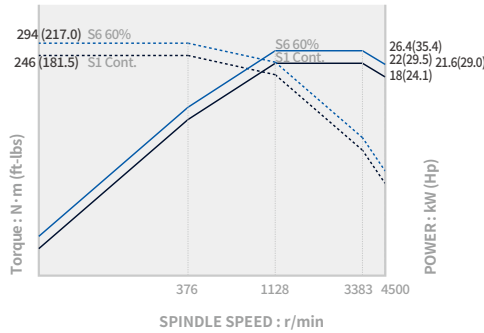

PUMA 2600_Belt type

Max. spindle speed
3500 r/min

Max. motor power
33.6 kW
(45.1 Hp)

Max. motor torque
617 N·m
(455.3 ft-lbs)

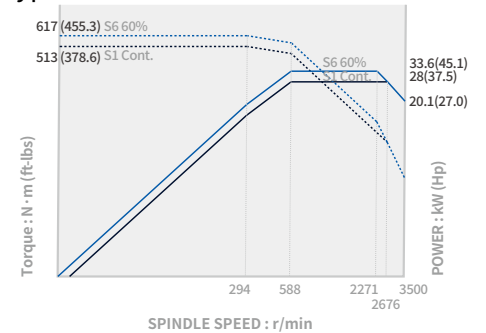

PUMA 3100_Belt type

Max. spindle speed
2800 r/min

Max. motor power
30 kW
(40.2 Hp)

Max. motor torque
1112 N·m
(820.7 ft-lbs)

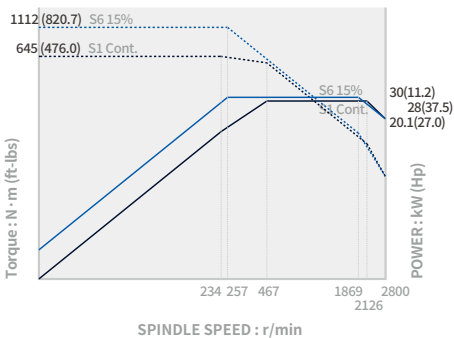

PUMA 3100_Built-in type

Max. spindle speed
3000 r/min

Max. motor power
30 kW
(40.2 Hp)

Max. motor torque
1240 N·m
(915.1 ft-lbs)

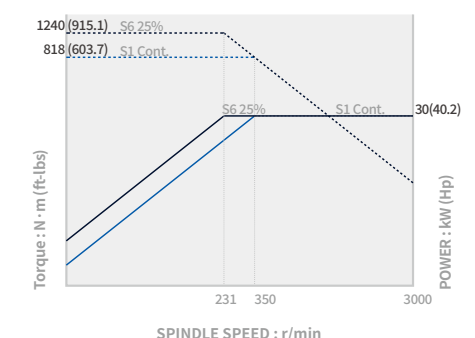

PUMA 2600, 2600/500, 2600M/500 series_Belt type

Max. spindle speed
4500 r/min

Max. motor power
8.3 kW
(11.1 Hp)

Max. motor torque
82 N·m
(60.5 ft-lbs)

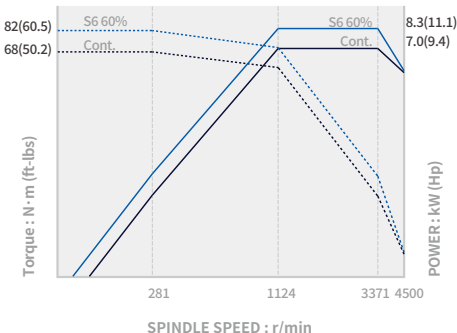

Max. spindle speed
5000 r/min

Max. motor power
7.79 kW
(10.4 Hp)

Max. motor torque
79.8 N·m
(58.9 ft-lbs)

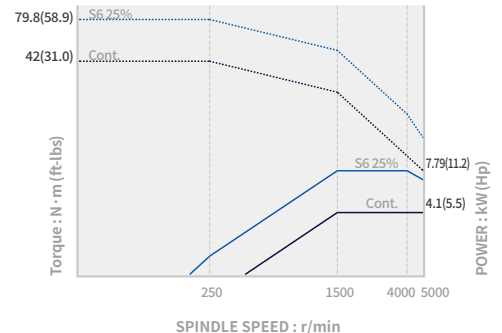

EXTERNAL DIMENSIONS

PUMA 2100 / 2600

Unit : mm (inch)

TOP VIEW

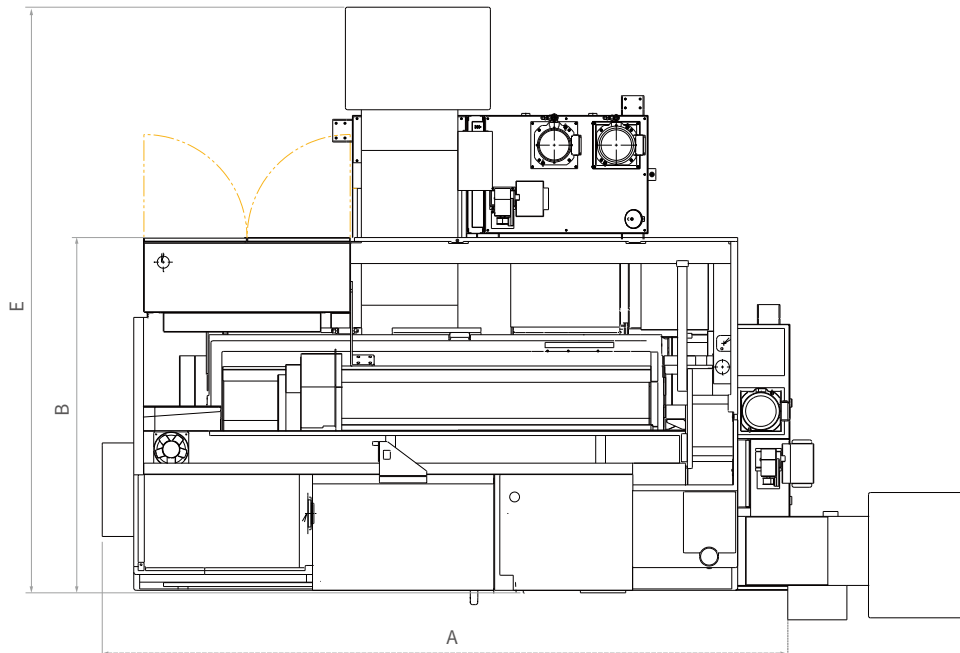

FRONT VIEW

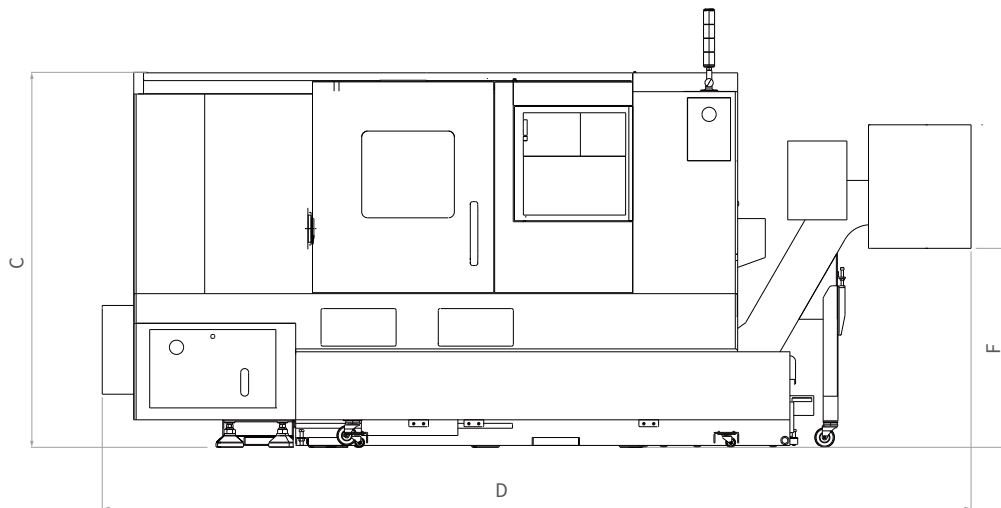

Model	A (Length)	B (Width)	C (Height)	D (Length with side chip conveyor)	E (Width with rear chip conveyor)	F (Height of ground to chip outlet)
PUMA 2100	3330 (131.1)	1905 (75.0)	1900 [2163] (74.8 [85.2])	4210 (165.7)	3074 (121.0)	1010 (39.8)
PUMA 2100L	3550 (139.8)	1905 (75.0)	1900 [2163] (74.8 [85.2])	4430 (174.4)	3074 (121.0)	1010 (39.8)
PUMA 2600/500	3430 (135.0)	1905 (75.0)	1900 (74.8)	4310 (169.7)	3074 (121.0)	1010 (39.8)
PUMA 2600	3650 (143.7)	1905 (75.0)	1900 [2163] (74.8 [85.2])	4530 (178.3)	3074 (121.0)	1010 (39.8)
PUMA 2600L	4335 (170.7)	2009 (79.1)	1900 [2163] (74.8 [85.2])	5389 (212.2)	-	1010 (39.8)
PUMA 2600B	3918 (154.3)	1905 (75.0)	1900 (74.8)	4798 (188.9)	3074 (121.0)	1010 (39.8)
PUMA 2600LB	4438 (174.7)	2009 (79.1)	1900 (74.8)	5492 (216.2)	-	1010 (39.8)

EXTERNAL DIMENSIONS

PUMA 3100

Unit : mm (inch)

TOP VIEW

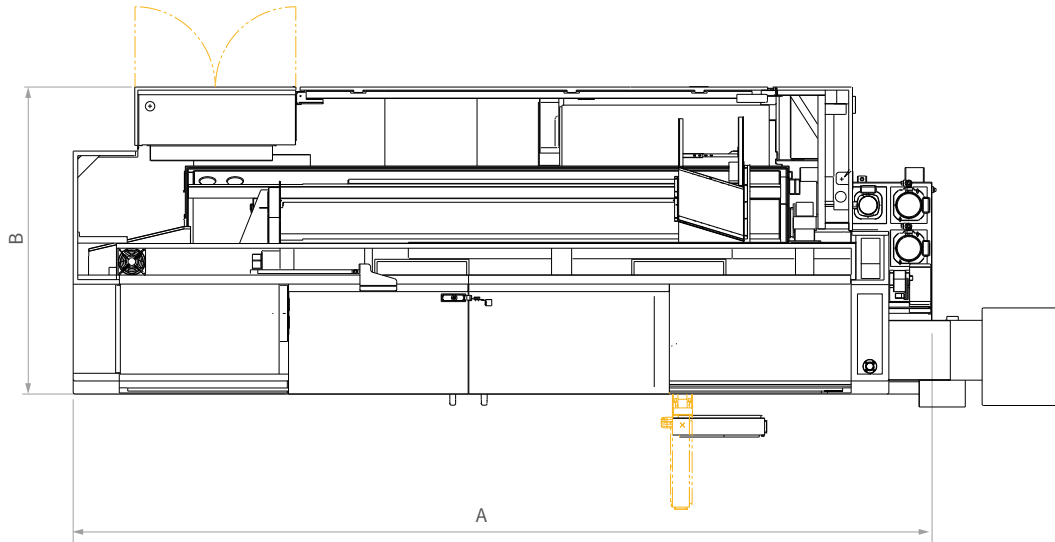

FRONT VIEW

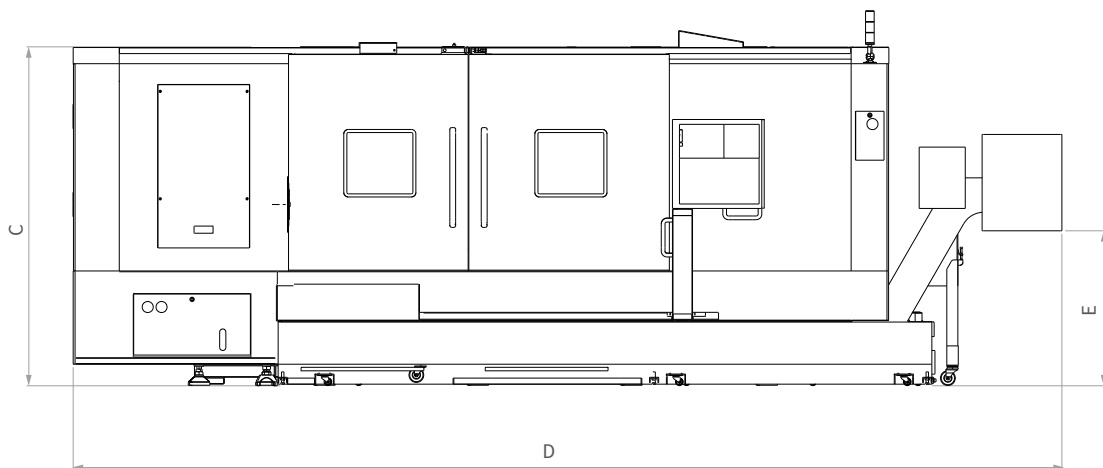

Model	A (Length)	B (Width)	C (Height)	D (Length with side chip conveyor)	E (Height of ground to chip outlet)
PUMA 3100	3908 (153.9)	1978 (77.9)	2010 [2315] (79.1 [91.1])	4819 (189.7)	1010 (39.8)
PUMA 3100L	4527 (178.2)	2067 (81.4)	2010 [2315] (79.1 [91.1])	5599 (220.4)	1010 (39.8)
PUMA 3100XL	5615 (221.1)	2280 (89.8)	2315 (91.1)	6443 (253.7)	1010 (39.8)
PUMA 3100UL	6585 (259.3)	2280 (89.8)	2315 (91.1)	7670 (302.0)	1010 (39.8)
PUMA 3100LYB	5857 (230.6)	2280 (89.8)	2315 (91.1)	6685 (263.2)	1010 (39.8)
PUMA 3100LYB	6827(268.8)	2280 (89.8)	2315 (91.1)	7912 (311.5)	1010 (39.8)

* Some peripheral equipment can be placed in other places

TOOLING SYSTEM

Unit : mm (inch)

PUMA 2100 / 2100L / 2600 / 2600L

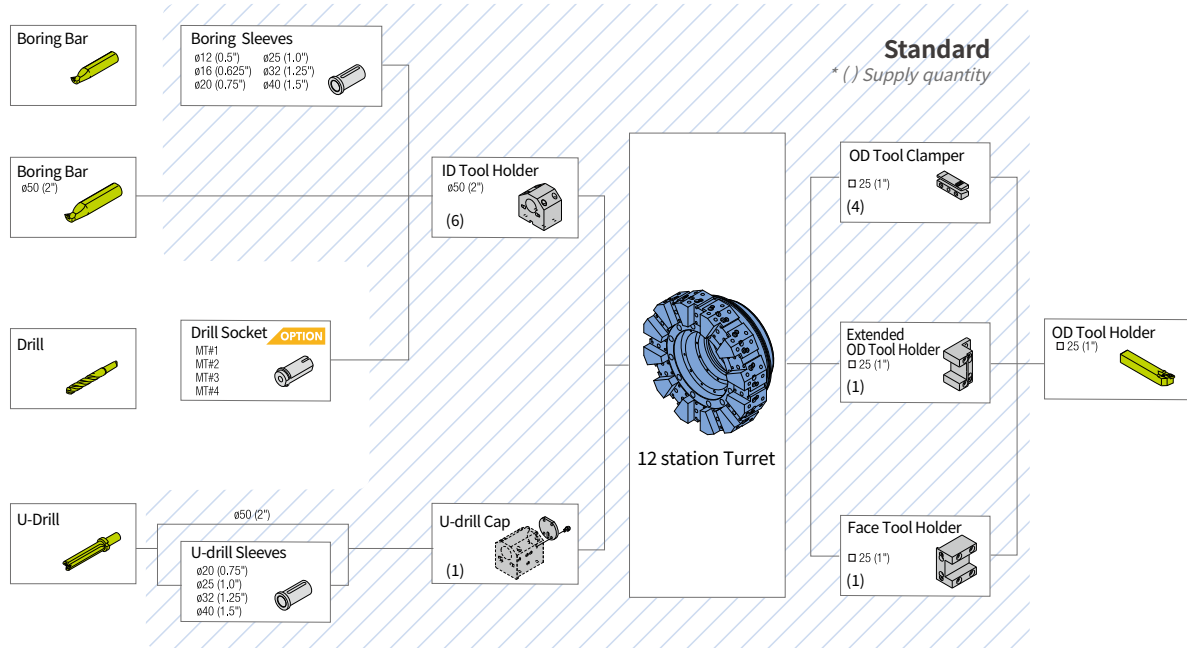

PUMA 2100S / 2100LS / 2600S / 2600LS

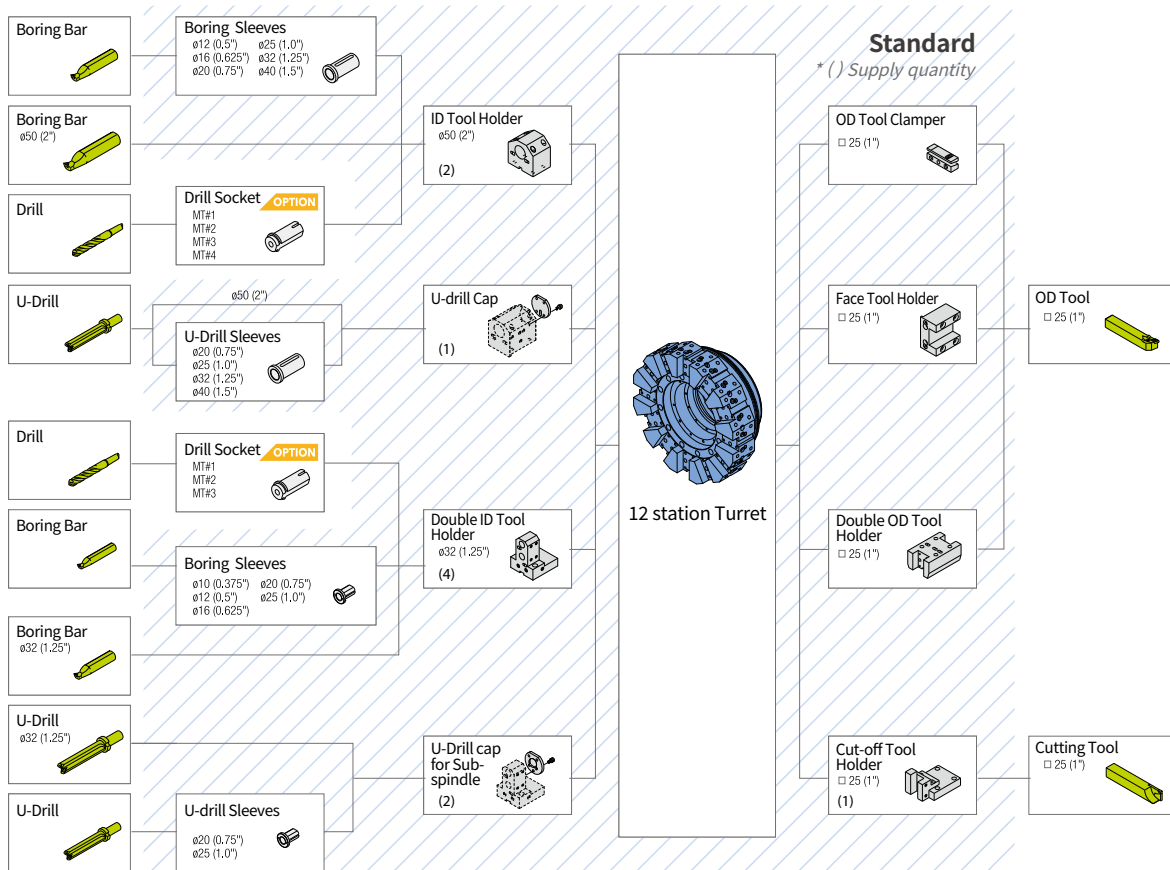

TOOLING SYSTEM

PUMA 2100M / 2100LM / 2100Y / 2100LY

Unit : mm (inch)

12 station-BMT55P

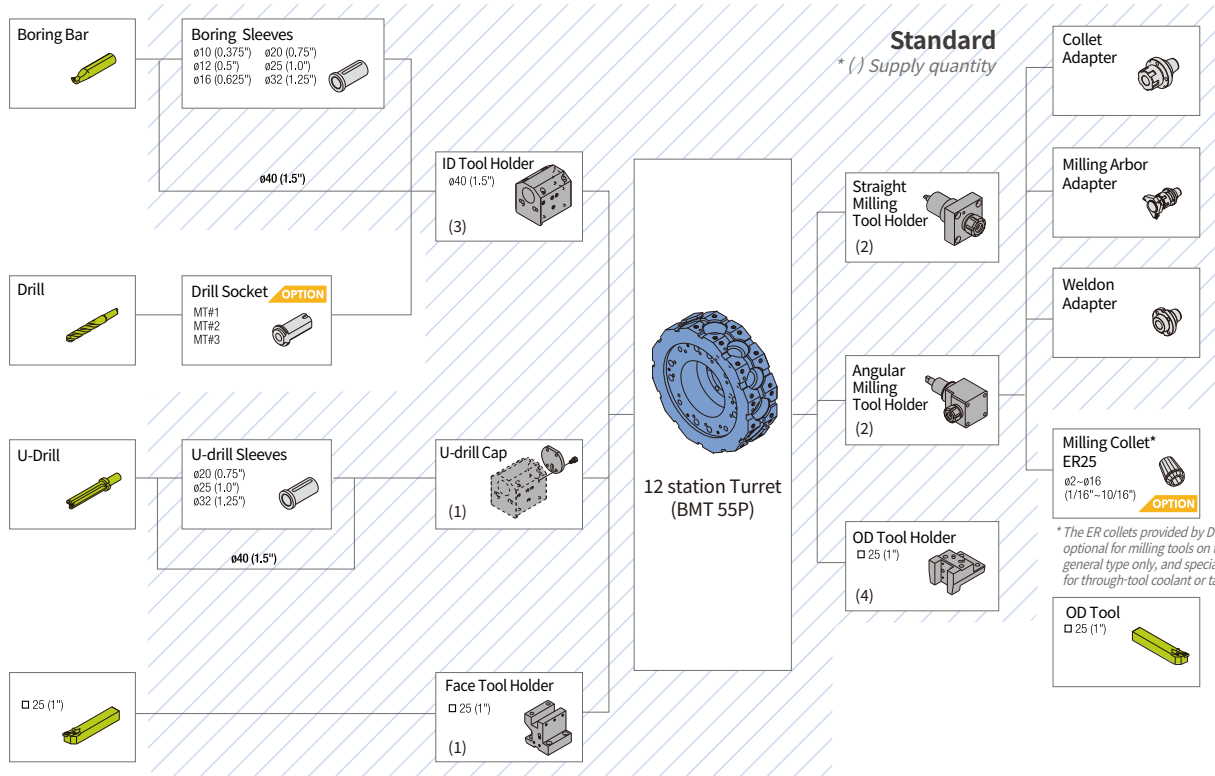

24 station- BMT55P OPTION

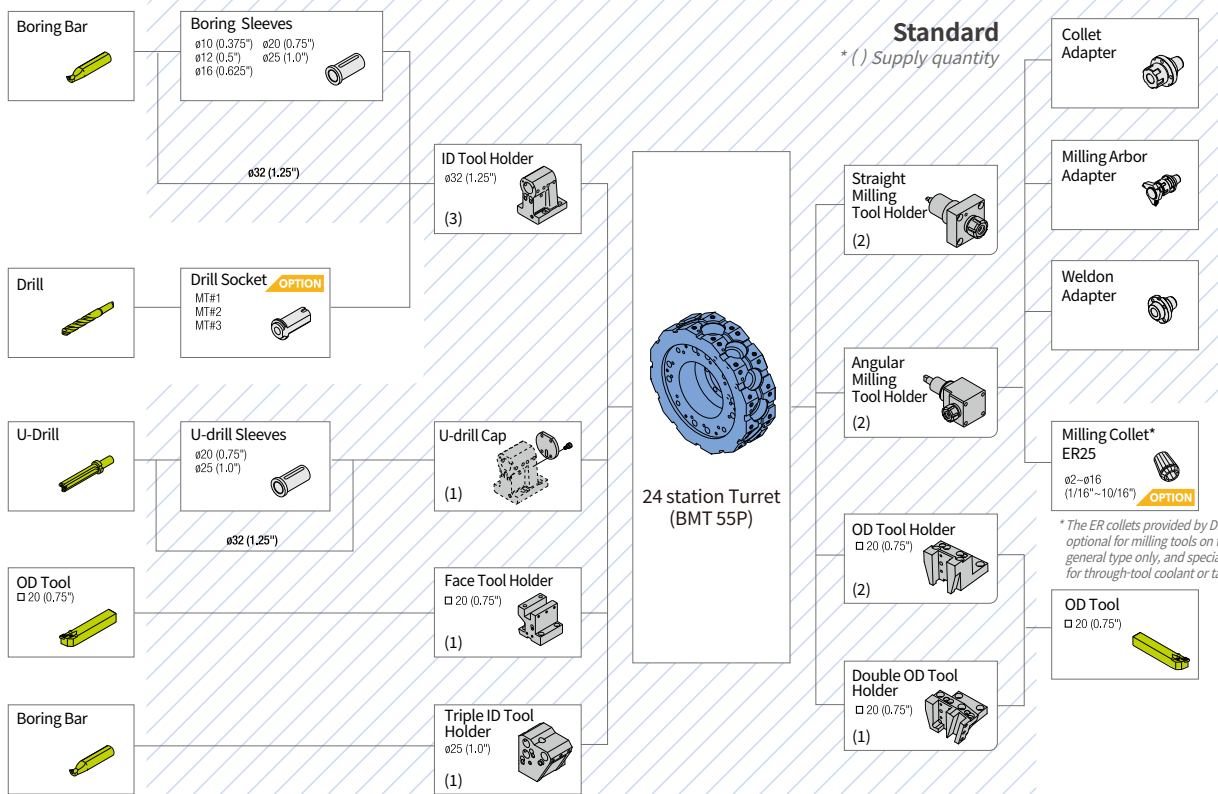

TOOLING SYSTEM

PUMA 2100MS / 2100LMS / 2100SY / 2100LSY

Unit : mm (inch)

12 station-BMT55P

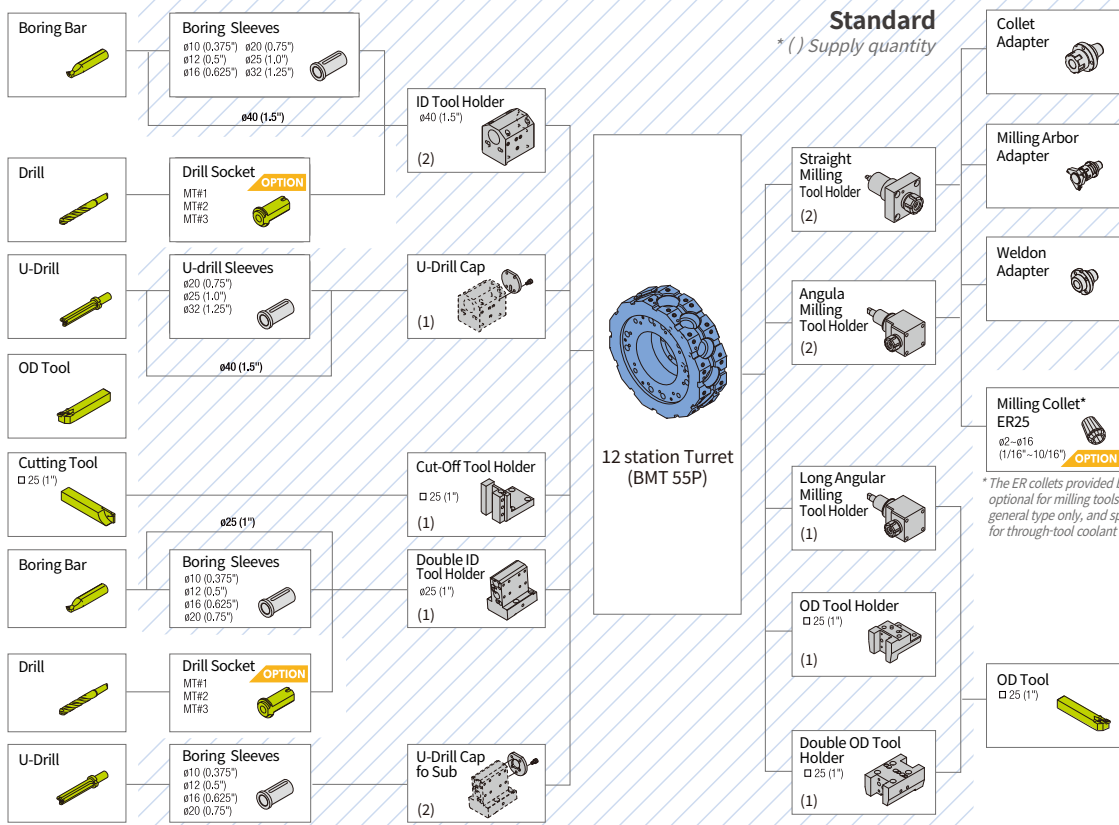

24 station- BMT55P OPTION

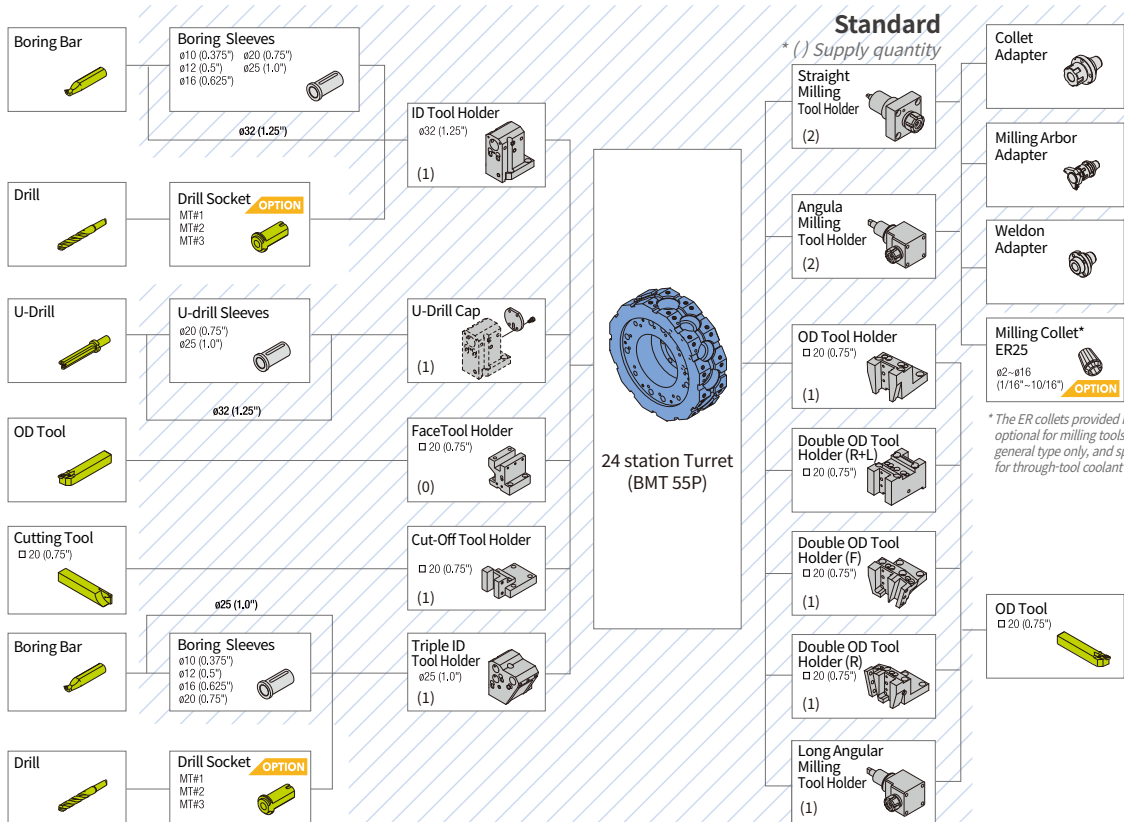

TOOLING SYSTEM

PUMA 2600M / 2600LM / 2600Y / 2600LY

Unit : mm (inch)

12 station-BMT65P

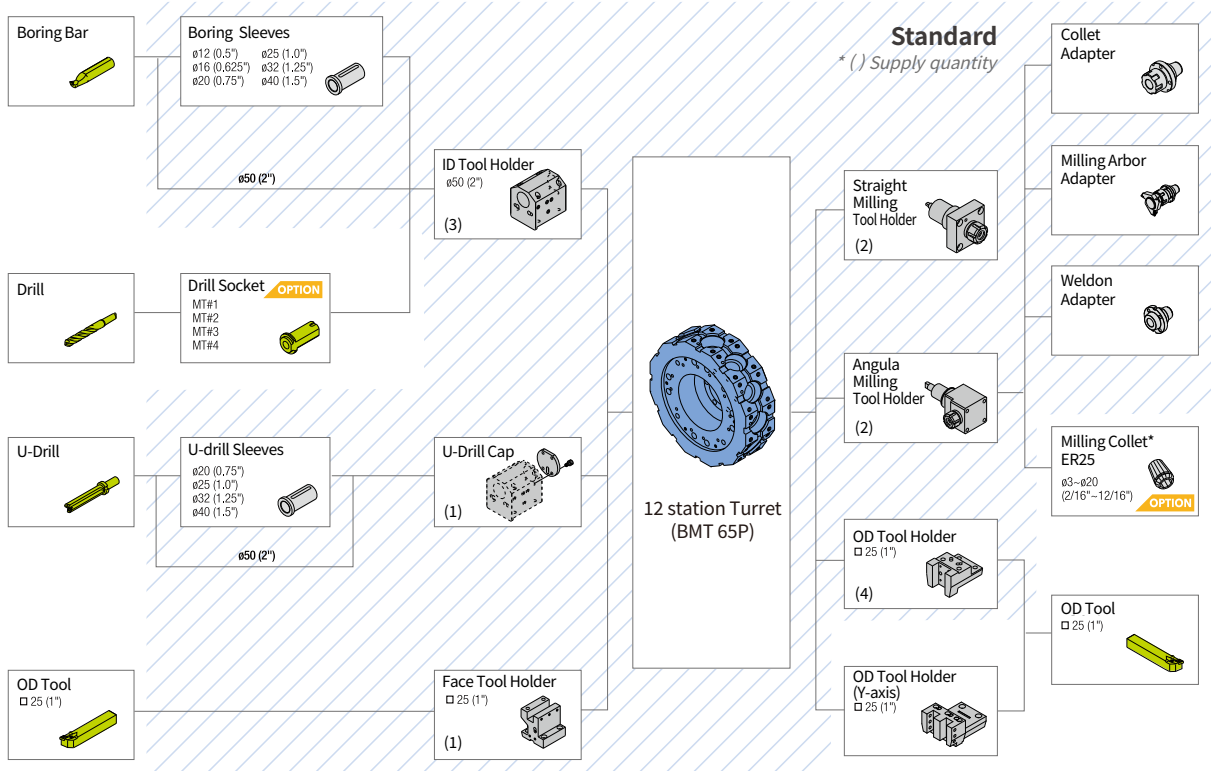

24 station- BMT65P **OPTION**

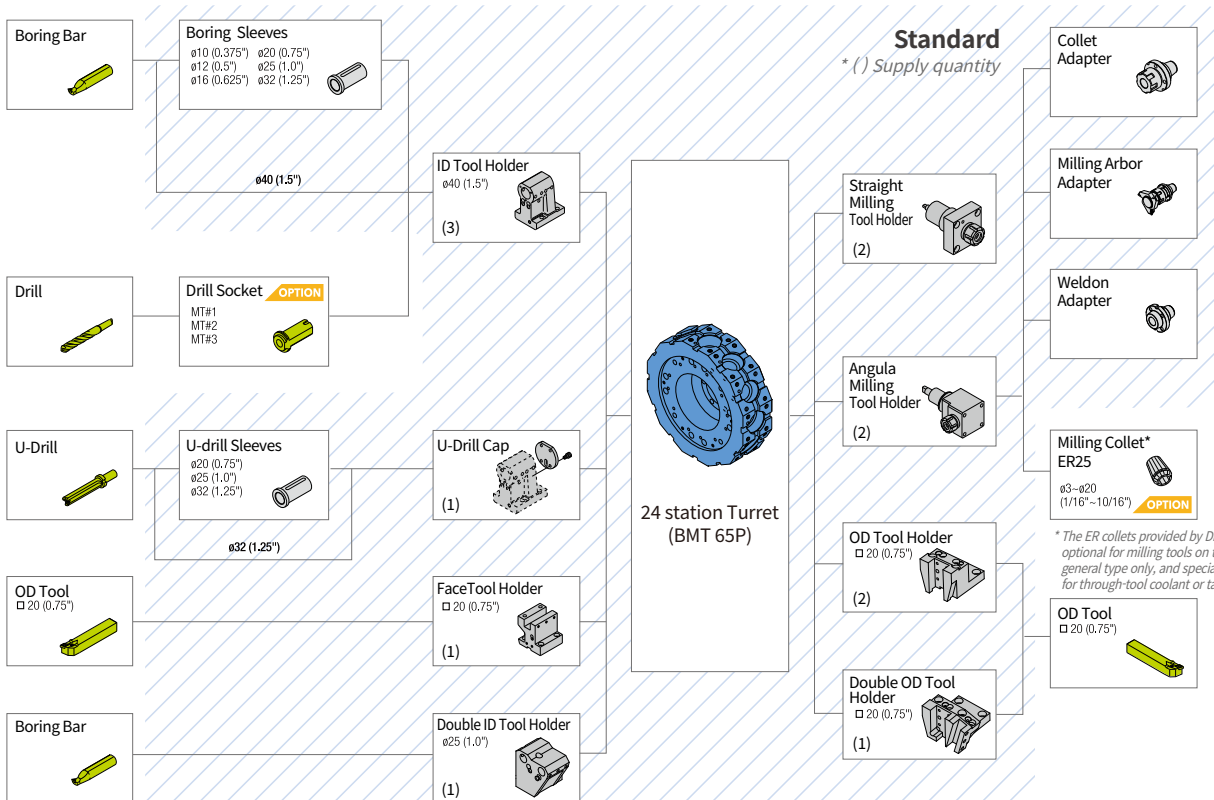

TOOLING SYSTEM

PUMA 2600MS / 2600LMS / 2600SY / 2600LSY

Unit : mm (inch)

12 station-BMT65P

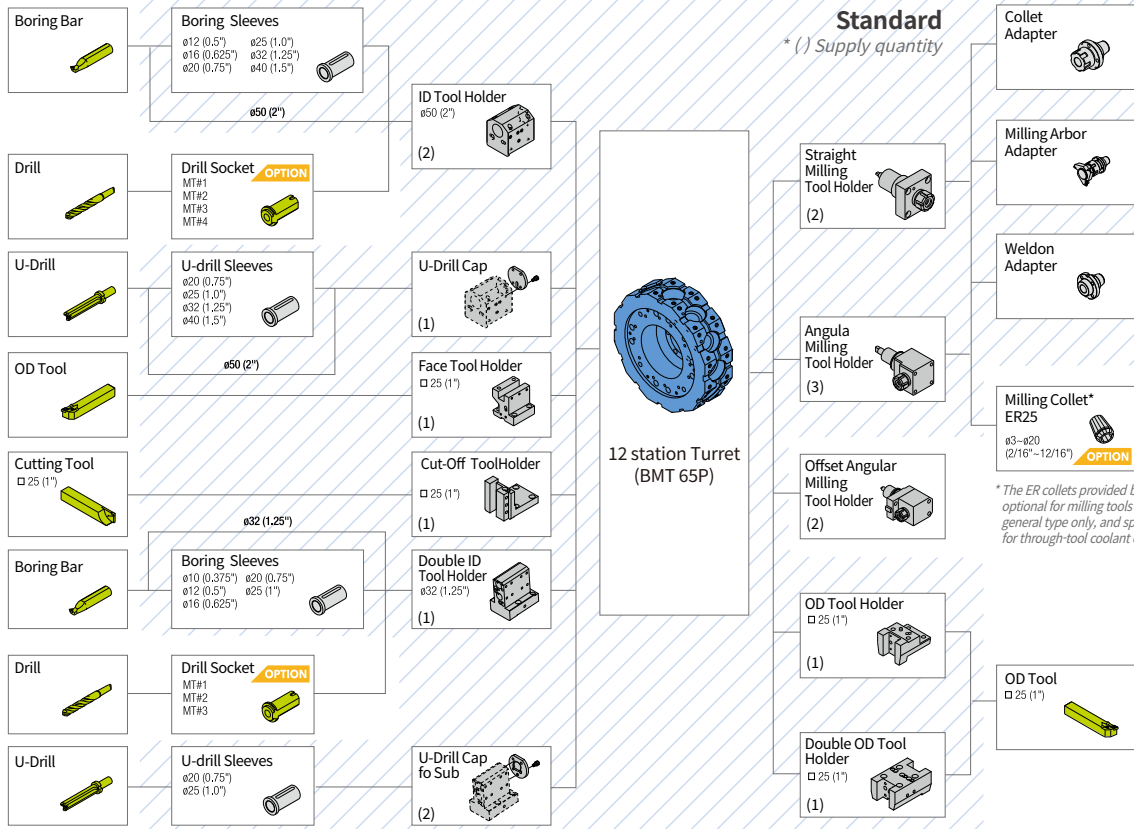

24 station- BMT65P (OPTION)

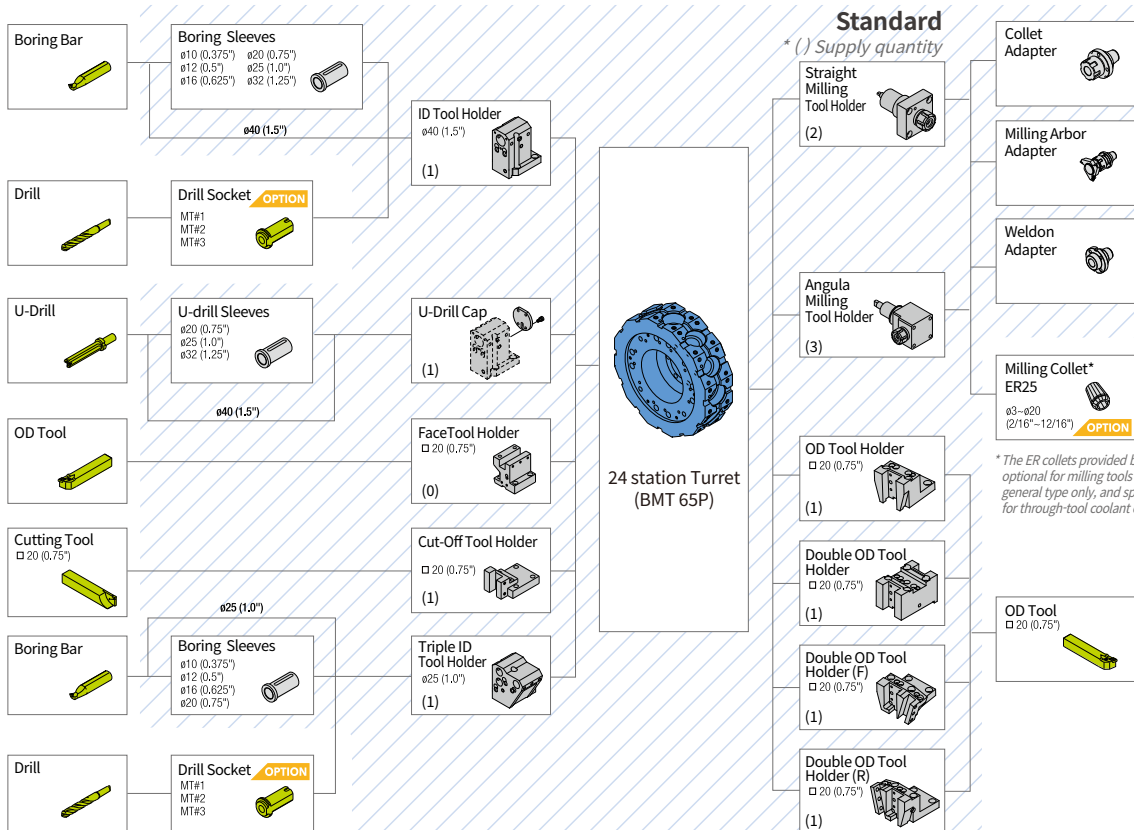

TOOLING SYSTEM

Unit : mm (inch)

PUMA 3100 / 3100L / 3100XL / 3100UL

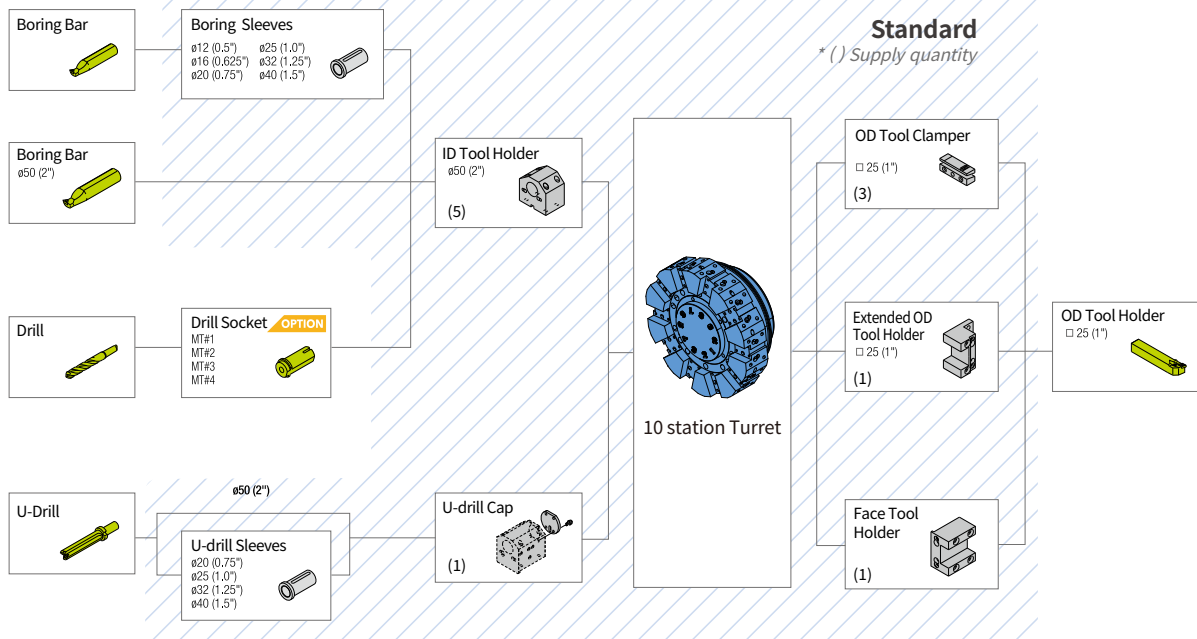

PUMA 3100M / 3100LM / 3100XLM / 3100ULM / 3100Y / 3100LY / 3100 XLY / 3100ULY

12 station- BMT65P

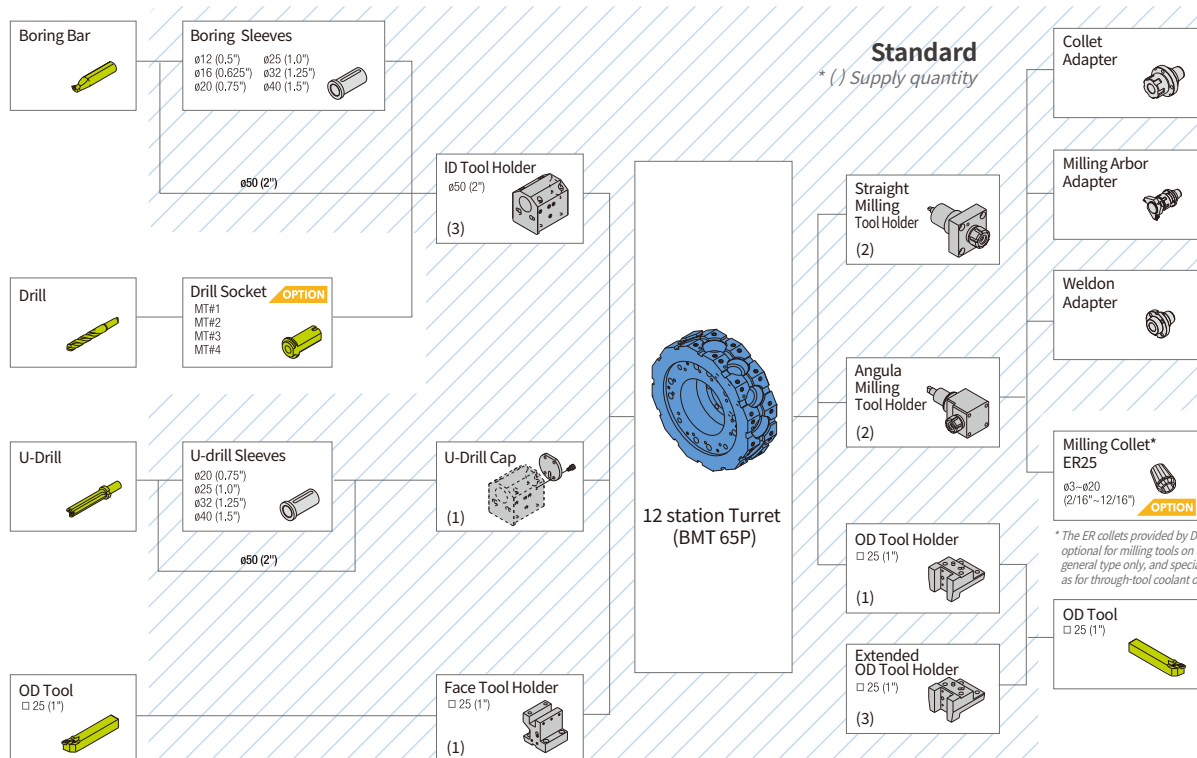

TOOL INTERFERENCE

Unit : mm (inch)

PUMA 2100M / 2100LM / 2600M / 2600LM

12 station-BMT65P

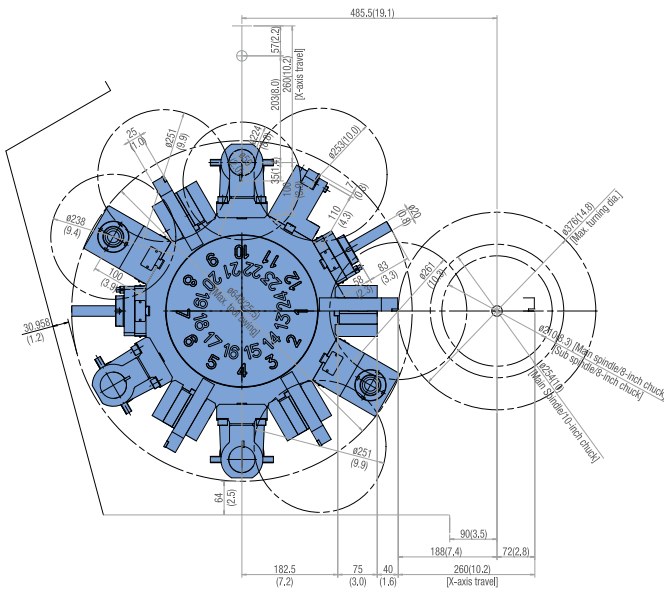

PUMA 2100MS / 2100LMS / 2600MS / 2600LMS

12 station-BMT65P

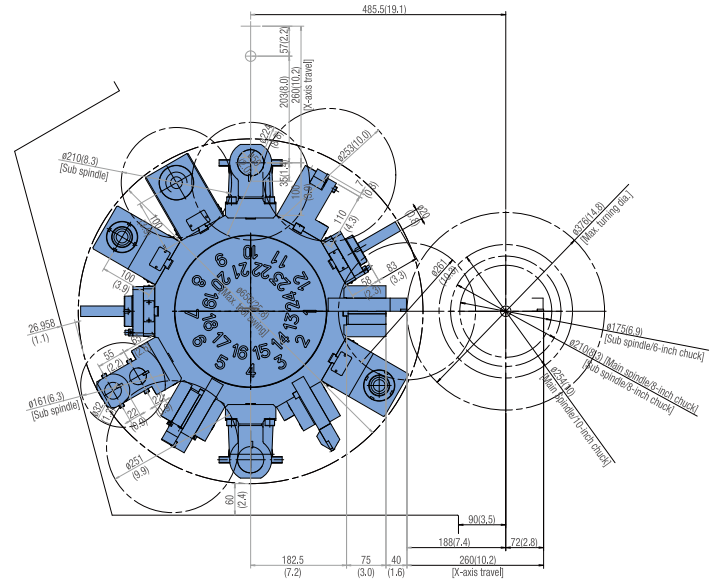

PUMA 2100M / 2100LM

24 station- BMT55P

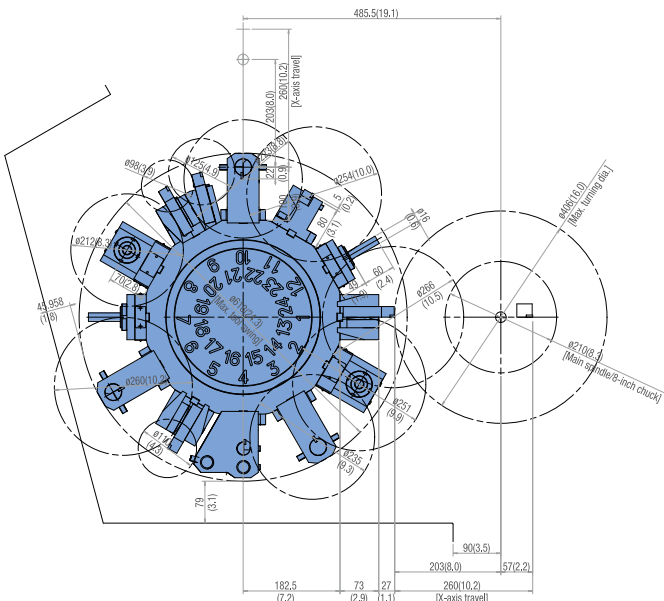

PUMA 2100MS / 2100LMS

24 station- BMT55P

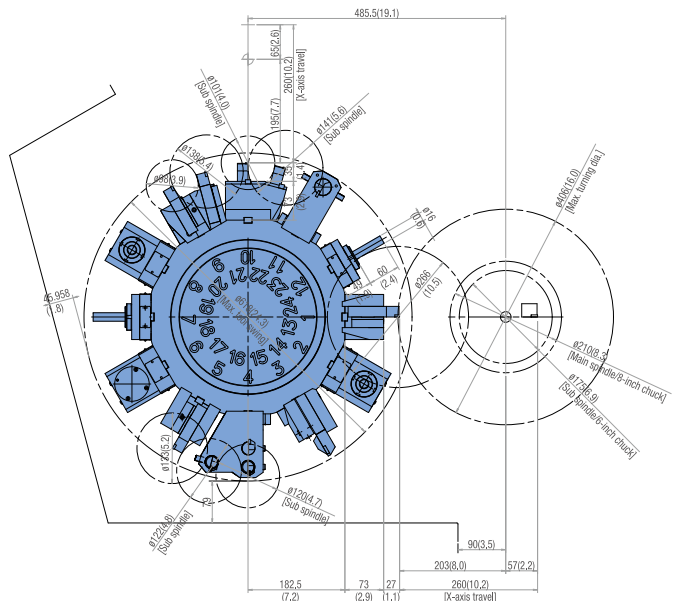

TOOL INTERFERENCE

Unit : mm (inch)

PUMA 2100M / 2100LM / 2600M / 2600LM

24 station-BMT65P

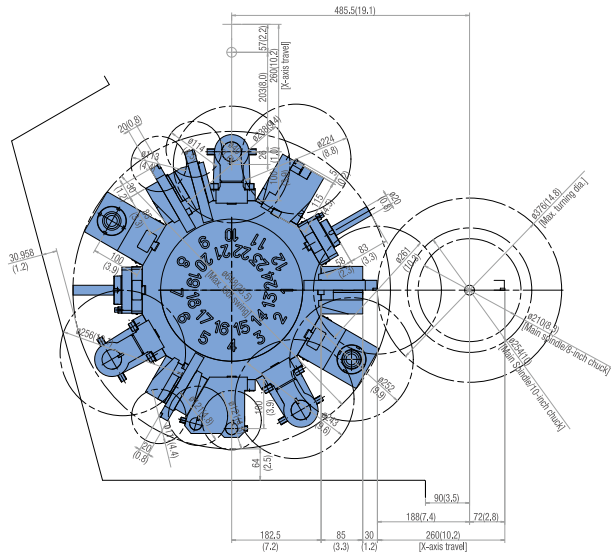

PUMA 2100MS / 2100LMS / 2600MS / 2600LMS

24 station-BMT65P

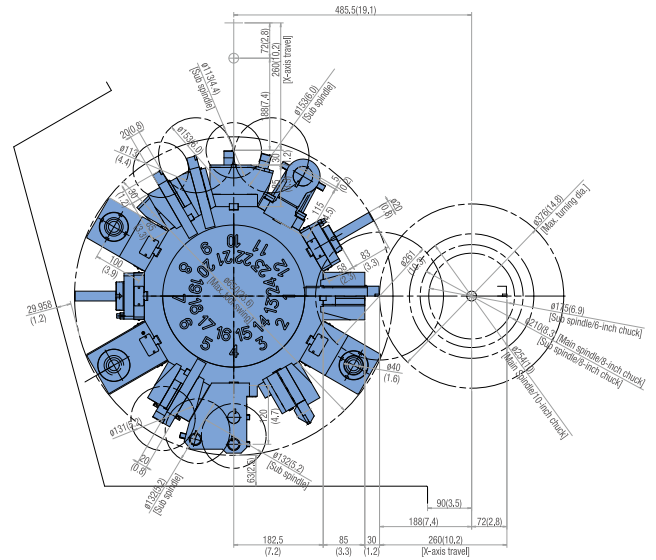

PUMA 2100SY / 2100LSY

12 station-BMT55P

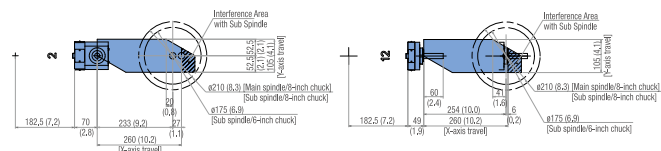
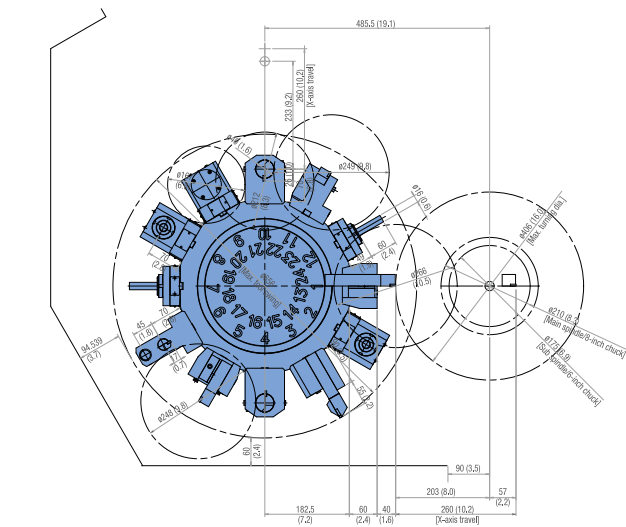

PUMA 2100Y / 2100LY

12 station-BMT55P

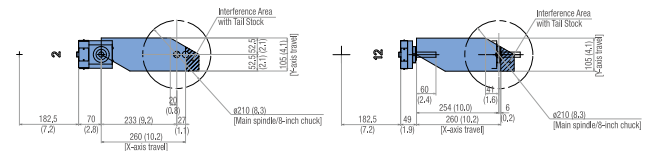
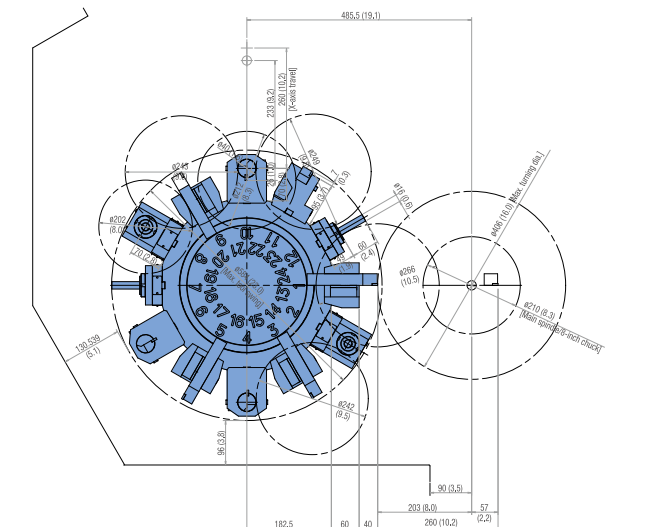

TOOL INTERFERENCE

Unit : mm (inch)

PUMA 2100SY / 2100LSY / 2600SY / 2600LSY

12 station-BMT65P

PUMA 2100Y / 2100LY / 2600Y / 2600LY

12 station-BMT65P

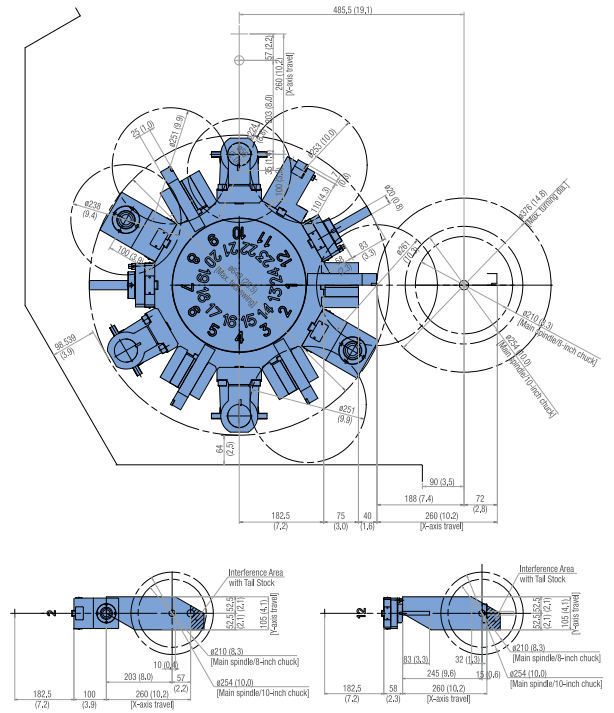
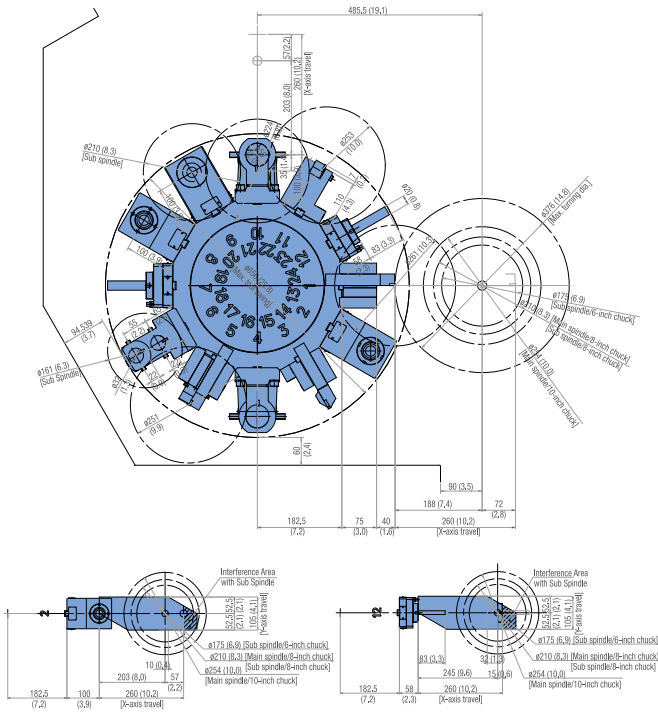

PUMA 2100SY / 2100LSY

24 station- BMT55P

PUMA 2100Y / 2100LY

24 station- BMT55P

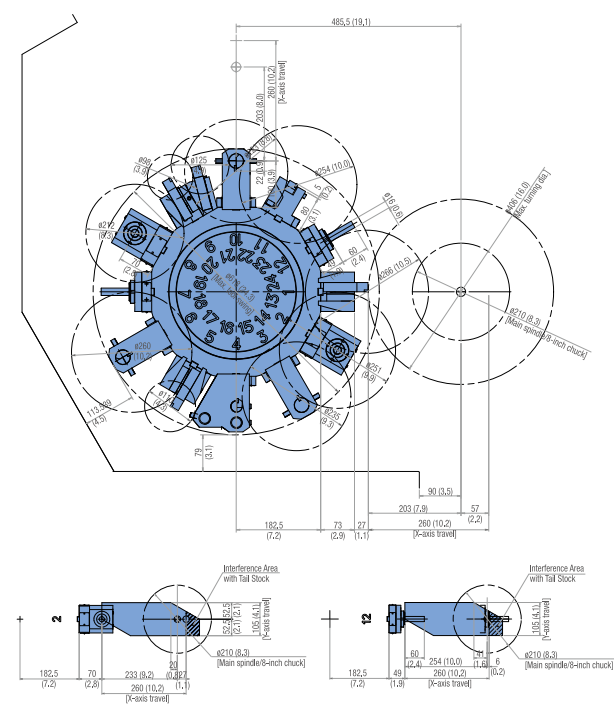
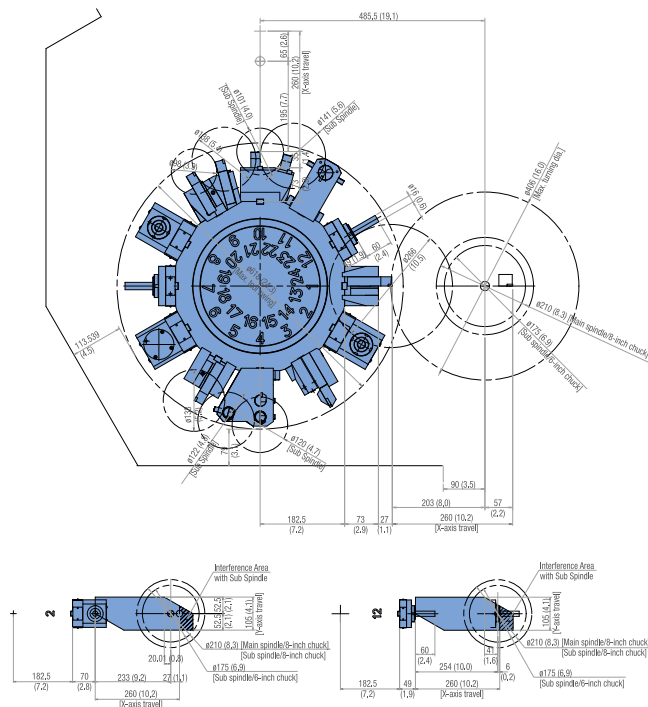

TOOL INTERFERENCE

Unit : mm (inch)

PUMA 2100SY / 2100LSY / 2600SY / 2600LSY

24 station-BMT65P

PUMA 2100Y / 2100LY / 2600Y / 2600LY

24 station-BMT65P

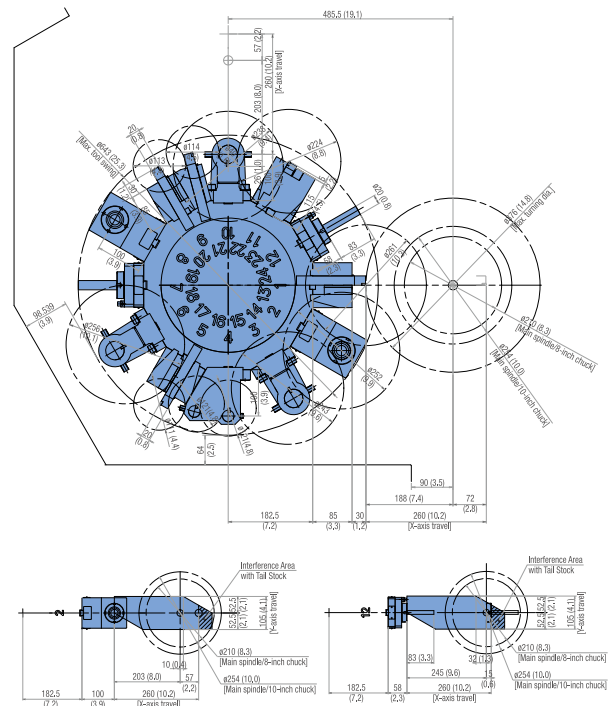
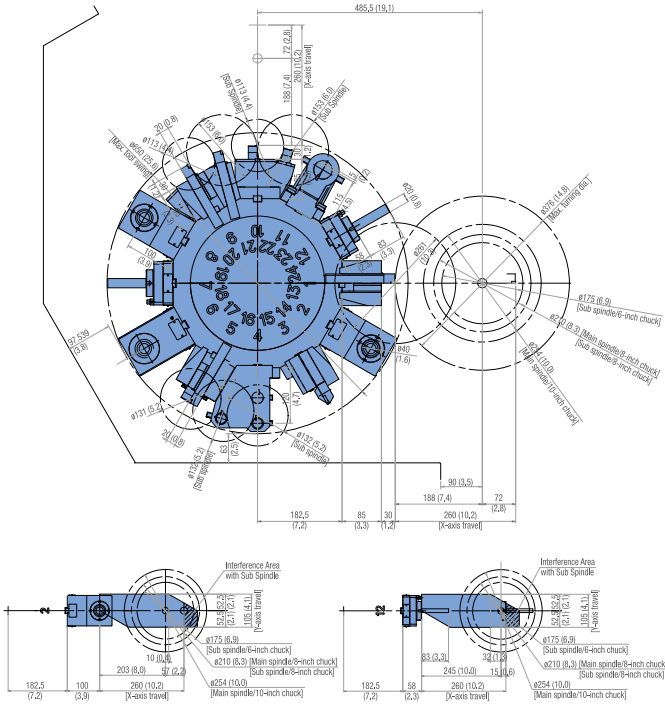

PUMA 3100 / 3100L

10 station

PUMA 3100XL / 3100UL

10 station

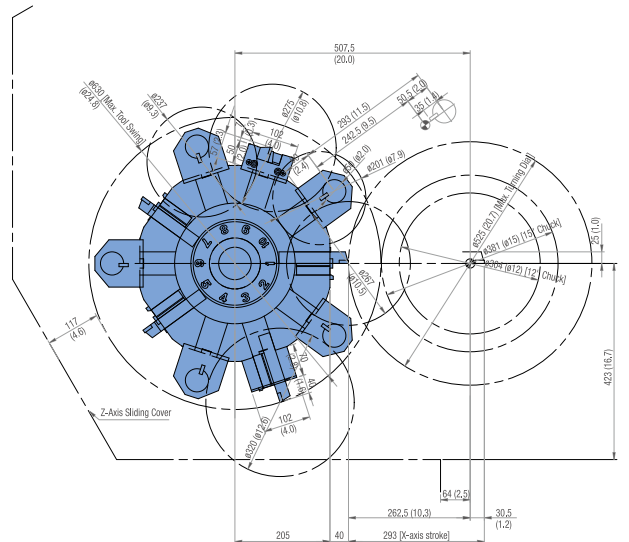
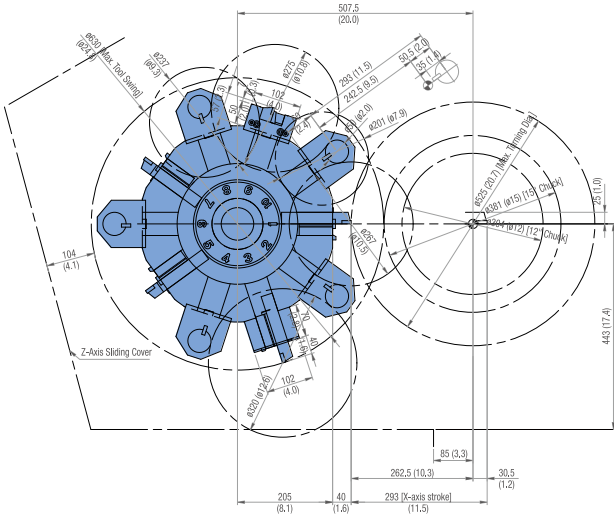

TOOL INTERFERENCE

Unit : mm (inch)

PUMA 3100M / 3100LM / 3100Y / 3100LY

12 station-BMT65P

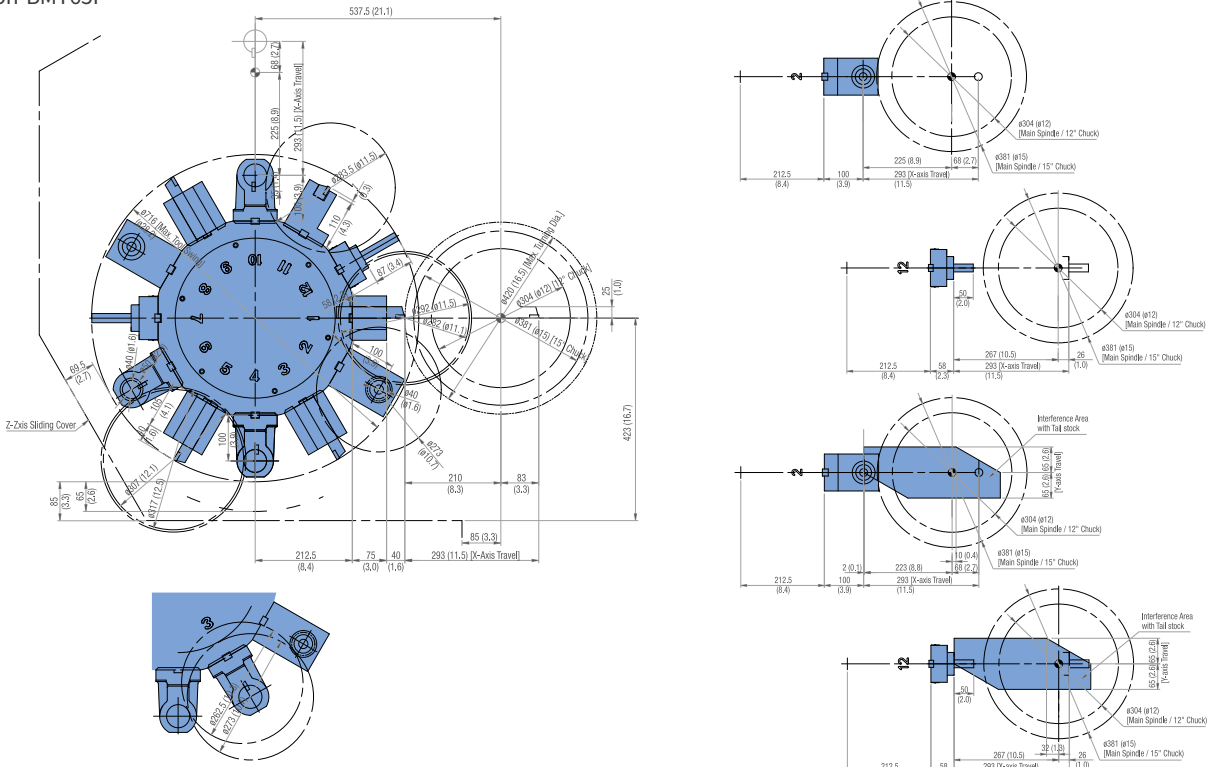

PUMA 3100XLM / 3100ULM / 3100 XLY / 3100ULY

12 station-BMT65P

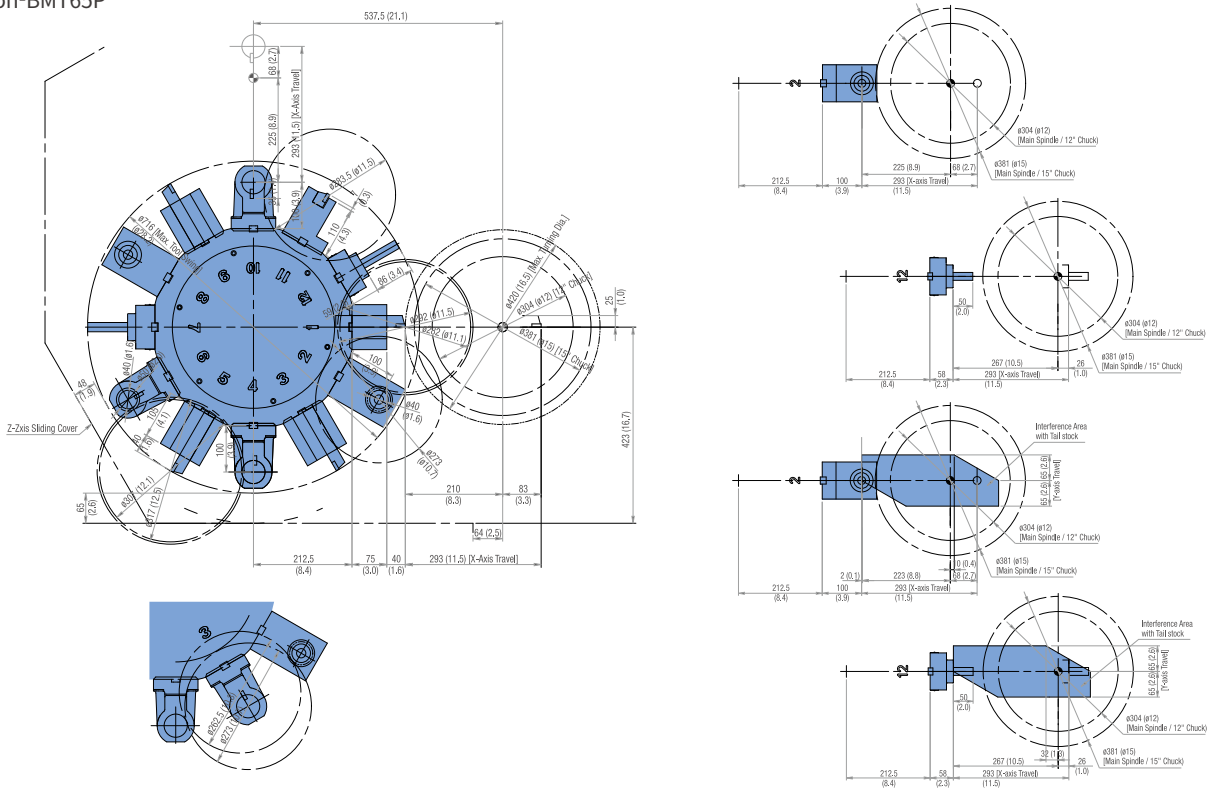

MACHINE SPECIFICATIONS

PUMA 2100 series

Description		Unit	PUMA 2100/L	PUMA 2100M/LM	PUMA 2100MS/LMS	PUMA 2100Y/LY	PUMA 2100SY/LSY
Capacity	Swing over bed	mm (inch)	780 (30.7)				
	Swing over front door	mm (inch)	630 (24.8)				
	Swing over saddle*	mm (inch)	680 (26.8)				
	Recom. Turning diameter	mm (inch)	210 (8.3)				
	Max. turning diameter	mm (inch)	481 (18.9)		406 (16.0)		
	Max. turning length	mm (inch)	545 / 785 (21.5 / 30.9)		520 / 760 (20.5 / 29.9)		
	Bar working diameter	mm (inch)	65 (2.6)				
Travels	Travel distance	X-axis	260 (10.2)				
		Z-axis	590 / 830 (23.2 / 32.7)				
		Y-axis	-				
		B-axis	mm (inch)	-	590 / 830 (23.2 / 32.7)	-	590 / 830 (23.2 / 32.7)
Feedrates	Rapid traverse	X-axis	30 (1181.1)				
		Z-axis	30 (1181.1)				
		Y-axis	-				
		B-axis	mm (inch)	-	30 (1181.1)	-	30 (1181.1)
Spindle	Spindle speed (Belt Type)	r/min	4500				
	Spindle speed (Built-in Type)	r/min	-				
	Spindle nose		ASA A2#6				
	Spindle bearing diameter (Front)	mm (inch)	120 (4.7)				
	Spindle through hole diameter	mm (inch)	76 (3.0)				
	Min. spindle indexing angle (C-axis)	deg	-	0.001			
Turret	No. of tool stations	st	12	12 {24}*		12 {24} {16}*	
	OD tool size	mm (inch)	25 (1.0)	25 {20}*		25 {20} {25}*	
	Boring bar diameter	mm (inch)	50 (2.0)	40 {32}*		40 {32} {32}*	
	Indexing time (1st swivel time)	s	0.15				
	Rotary tool spindle speed	r/min	-	5000			
Tail stock	Quill diameter	mm (inch)	80 (3.1)	-	80 (3.1)	-	
	Quill bore taper (Live)		MT#4	-	MT#4	-	
	Compressed air supply	mm (inch)	80	-	80 (3.1)	-	
Sub-spindle	Spindle speed (Belt [Built-in])	r/min	-	4500	-	4500 [PUMA 2100SY II /LSY II]	
	Spindle nose		-	ASA A2-5	-	ASA A2-5	
	Spindle bearing diameter (Front)	mm (inch)	-	90 (3.5)	-	90 (3.5)	
	Spindle through hole diameter	mm (inch)	-	62 (2.4)	-	62 (2.4)	
	Min. spindle indexing angle (C-axis)	deg	-	0.001	-	0.001	
Motors	Main spindle motor	kW (Hp)	25 / 18.5 / 15 (33.5 / 24.8 / 20.1) (S6 25% / S6 60% / S1 Cont.)				
	Sub spindle motor	kW (Hp)	-	7.5 / 5.5 (10 / 7)	-	7.5 / 5.5 (10 / 7)	
	Rotary tool spindle motor	kW (Hp)	-	5.5 (7)			
	Coolant pump motor	kW (Hp)	0.4 (0)				
Power source	Electric power supply (Rated capacity)	kVA	32.78	33.7	46.56	41.32	48.54
Machine size	Machine height	mm (inch)	1900 (74.8)			2163 (85.2)	
	Machine dimension	length	3330 / 3530 (131.1 / 139.0)				
		width	1863 (73.3)				
	Machine weight	kg (lb)	4850 / 5350 (10692.3 / 11794.6)	5000 / 5500 (11023.0 / 12125.2)	5450 / 5950 (12015.0 / 13117.3)	5450 / 5950 (12015.0 / 13117.3)	5900 / 6400 (13007.1 / 14109.4)

{ } : Option

* The specifications and information above-mentioned may be changed without prior notice.

* For more details, please contact DN Solutions.

MACHINE SPECIFICATIONS

PUMA 2600 series

Description		Unit	PUMA 2600/L	PUMA 2600M/LM	PUMA 2600MS/LMS/LMSB	PUMA 2600Y/LY	PUMA 2600SY/LSY/LSYB
Capacity	Swing over bed	mm (inch)	780 (30.7)				
	Swing over front door	mm (inch)	630 (24.8)				
	Swing over saddle*	mm (inch)	680 (26.8)				
	Recom. Turning diameter	mm (inch)	255 (10.0)				
	Max. turning diameter	mm (inch)	481 (18.9)	376 (14.8)			
	Max. turning length	mm (inch)	790 / 1310 (31.1 / 51.6)	760 / 1280 (29.9 / 50.4)			
	Bar working diameter	mm (inch)	76 (3.0)				
Travels	Travel distance	X-axis	260 (10.2)				
		Z-axis	830 / 1350 (32.7 / 53.1)				
		Y-axis	-	105 (±52.5)			
		B-axis	-	830 / 1350 (32.7 / 53.1)	-	830 / 1350 (32.7 / 53.1)	
Feedrates	Rapid traverse	X-axis	30 (1181.1)				
		Z-axis	30 (1181.1)				
		Y-axis	-	10 (393.7)			
		B-axis	-	30 (1181.1)	-	30 (1181.1)	
Spindle	Spindle speed (Belt Type)	r/min	3500				
	Spindle speed (Built-in Type)	r/min	-	PUMA 2600Y II series			
	Spindle nose		ASA A2#8				
	Spindle bearing diameter (Front)	mm (inch)	140 (5.5)				
	Spindle through hole diameter	mm (inch)	86 (3.4)				
	Min. spindle indexing angle (C-axis)	deg	-	0.001			
Turret	No. of tool stations	st	12	12 {24}*			
	OD tool size	mm (inch)	25 (1.0)	25 {20}*			
	Boring bar diameter	mm (inch)	50 (2.0)	50 {40}*			
	Indexing time (1st swivel time)	s	0.15				
	Rotary tool spindle speed	r/min	-	5000			
Tail stock	Quill diameter	mm (inch)	100 (3.9)	-	100 (3.9)	-	
	Quill bore taper (Live)		MT#5	-	MT#5	-	
	Compressed air supply	mm (inch)	100 (3.9)	-	100 (3.9)	-	
Sub-spindle	Spindle speed (Belt [Built-in])	r/min	-	4500	-	4500 [PUMA 2600SY II /LSY II]	
	Spindle nose		-	ASA A2-5	-	ASA A2-5	
	Spindle bearing diameter (Front)	mm (inch)	-	90 (3.5)	-	90 (3.5)	
	Spindle through hole diameter	mm (inch)	-	62 (2.4)	-	62 (2.4)	
	Min. spindle indexing angle (C-axis)	deg	-	0.001	-	0.001	
Motors	Main spindle motor	kW (Hp)	30 / 22 / 18.5 (40.2 / 29.5 / 24.8) (S6 25% / S6 60% / S1 Cont.)				
	Sub spindle motor	kW (Hp)	-	7.5 / 5.5 (10 / 7)	-	7.5 / 5.5 (10 / 7)	
	Rotary tool spindle motor	kW (Hp)	-	5.5 {7.5}* (7 {10})			
	Coolant pump motor	kW (Hp)	0.4 (0)				
Power source	Electric power supply (Rated capacity)	kVA	40.72	44.42	52.57	46.40	54.55
Machine size	Machine height	mm (inch)	1900 (74.8)			2163 (85.2)	
	Machine dimension	length	3650 / 4335 (143.7 / 170.7)				
		width	1863 / 1965 (73.3 / 77.4)				
	Machine weight	kg (lb)	5400 / 6700 (11904.8 / 14770.8)	5550 / 6850 (12235.5 / 15101.4)	6000 / 7300 (13227.5 / 16093.5)	6000 / 7300 (13227.5 / 16093.5)	6450 / 7750 (14219.6 / 17085.6)

{ } : Option

* The specifications and information above-mentioned may be changed without prior notice.

* For more details, please contact DN Solutions.

MACHINE SPECIFICATIONS

PUMA 2600 series

Description		Unit	PUMA 2600/500	PUMA 2600M/500	PUMA 2600B/LB	PUMA 2600MB/LMB	PUMA 2600SB	PUMA 2600MSB	
Capacity	Swing over bed	mm (inch)	780 (30.7)				780 (30.7)		
	Swing over front door	mm (inch)	630 (24.8)				630 (24.8)		
	Swing over saddle*	mm (inch)	680 (26.8)				680 (26.8)		
	Recom. Turning diameter	mm (inch)	255 (10.0)		305 (12.0)		305 (12.0)		
	Max. turning diameter	mm (inch)	481 (18.9)	376 (14.8)	481 (18.9)	376 (14.8)	481 (18.9)	376 (14.8)	
	Max. turning length	mm (inch)	550 (21.7)	520 (20.5)	755 / 1275 (29.7 / 50.2)	725 / 1245 (28.5 / 49.0)	755 (29.7)	725 (28.5)	
	Bar working diameter	mm (inch)	65 (2.6)		102 (4.0)		102 (4.0)		
Travels	Travel distance	X-axis	260 (10.2)				260 (10.2)		
		Z-axis	590 (23.2)		830 / 1350 (32.7 / 53.1)		830 (32.7)		
		Y-axis	-				-		
		B-axis	-				830 (32.7)		
Feedrates	Rapid traverse	X-axis	30 (1181.1)				30 (1181.1)		
		Z-axis	30 (1181.1)				30 (1181.1)		
		Y-axis	-				-		
		B-axis	-				30 (1181.1)		
Spindle	Spindle speed (Belt Type)	r/min	3500		2800				
	Spindle nose		ASA A2-8		A2-11		ASA A2-11		
	Spindle bearing diameter (Front)	mm (inch)	140 (5.5)		160 (6.3)		160 (6.3)		
	Spindle through hole diameter	mm (inch)	86 (3.4)		115 (4.5)		115 (4.5)		
	Min. spindle indexing angle (C-axis)	deg	0.001				-		0.001
Turret	No. of tool stations	st	12	12 {24}*	12	12 {24}*	12	12 {24}*	
	OD tool size	mm (inch)	25 (1.0)	25 {20}* (1.0 {0.8})	25	25 {20}* (1.0 {0.8})	25 (1.0)	25 {20}* (1.0 {0.8})*	
	Boring bar diameter	mm (inch)	50 (2.0)	50 {40}* (2.0 {1.6})	50	50 {40}* (2.0 {1.6})	50 (2.0)	50 {40}* (2.0 {1.6})*	
	Indexing time (1st swivel time)	s	0.15				0.15		
	Rotary tool spindle speed	r/min	-	5000	-	5000	-	5000	
Tail stock	Quill diameter	mm (inch)	100 (3.9)				100 (3.9)		
	Quill bore taper (Live)		MT#5				MT#5		
	Compressed air supply	mm (inch)	100 (3.9)				100 (3.9)		
Sub-spindle	Spindle speed (Belt [Built-in])	r/min	-				4500		
	Spindle nose		-				ASA A2#5		
	Spindle bearing diameter (Front)	mm (inch)	-				90 (3.5)		
	Spindle through hole diameter	mm (inch)	-				62 (2.4)		
	Min. spindle indexing angle (C-axis)	deg	-				0.001		
Motors	Main spindle motor	kW (Hp)	25/18.5/15 (33.5/30/25) (S6 25% / S6 60% / S1 Cont.)		26/22/18.5 (34.9/30/25) (S6 25% / S6 60% / S1 Cont.)		26/22/18.5 (34.9/30/25) (S6 25% / S6 60% / S1 Cont.)		
	Sub spindle motor	kW (Hp)	-				7.5 / 5.5 (10 / 7)		
	Rotary tool spindle motor	kW (Hp)	-	5.5 (7)	-	5.5 (7)	-	5.5 (7)	
	Coolant pump motor	kW (Hp)	0.4 (0)				0.4 (0)		
Power source	Electric power supply (Rated capacity)	kVA	33.44	40	40.72	44.42	48.86		
Machine size	Machine height	mm (inch)	1900 (74.8)				1900 (74.8)		
	Machine dimension	length	3430 (135.0)		3700/4438 (145.7/174.7)		3918 (154.3)		
		width	1863 (73.3)				1863 (73.3)		
	Machine weight	kg (lb)	4900 (10802.5)	5000 (11023.0)	5500 / 6800 (12125.2 / 14991.2)	5650 / 6950 (12455.9 / 15321.9)	5950 (13117.3)	6100 (13448.0)	

* The specifications and information above-mentioned may be changed without prior notice.

* For more details, please contact DN Solutions.

{ } : Option

MACHINE SPECIFICATIONS

PUMA 3100 series

Description		Unit	PUMA 3100 /L/XL/UL	PUMA 3100 M/LM/XLM/ULM	PUMA 3100 Y(SY)/LY(LSY)/XLY(B)/ULY(B)
Capacity	Swing over bed	mm (inch)	850 (33.5)		
	Swing over front door	mm (inch)	670 (26.4)		
	Swing over saddle*	mm (inch)	720 (28.3)** / 850 (33.5)***		
	Recom. Turning diameter	mm (inch)	315 (12.4)		315 (12.4) (XLYB/ULYB : 380(15.0))
	Max. turning diameter	mm (inch)	525 (20.7)		420 (16.5)
	Max. turning length	mm (inch)	790 / 1310 / 2150 / 3150 (31.1 / 51.6 / 84.6 / 124.0)		765 / 1285 / 2125 / 3125 (30.1 / 50.6 / 83.7 / 123.0)
	Bar working diameter	mm (inch)	102 (4.0)		102 (4.0) (XLYB/ULYB : 116.5(4.6))
Travels	Travel distance	X-axis	mm (inch)	293 {30.5+262.5} (11.5 {1.2+10.3})*	293 {83+210} (11.5 {3.3+8.3})*
		Z-axis	mm (inch)	830 / 1350 / 2190 / 3190(32.7 / 53.1 / 86.2 / 125.6)	
		Y-axis	mm (inch)	-	
		B-axis	mm (inch)	-	
Feedrates	Rapid traverse	X-axis	m/min (ipm)	30 (1181.1)	
		Z-axis	m/min (ipm)	30 / 30 / 30 / 26 (1181.1 / 1181.1 / 1181.1 / 1023.6)	
		Y-axis	m/min (ipm)	-	
		B-axis	m/min (ipm)	-	
Spindle	Spindle speed (Belt Type)	r/min	2800		2800 (XLYB/ULYB : 2000)
	Spindle speed (Built-in Type)	r/min	3000		3000 (XLYB/ULYB : N/A)
	Spindle nose		ASA A2#11		
	Spindle bearing diameter (Front)	mm (inch)	160 (6.3)		160 (6.3) (XLYB/ULYB : 180(7.1))
	Spindle through hole diameter	mm (inch)	115 (4.5)		115 (4.5) (XLYB/ULYB : 132(5.2))
Min. spindle indexing angle (C-axis)	deg	0.001			
Turret	No. of tool stations	st	10		12
	OD tool size	mm (inch)	25 (1.0)		
	Boring bar diameter	mm (inch)	50 (2.0)		
	Indexing time (1st swivel time)	s	0.15		
	Rotary tool spindle speed	r/min	-		5000
Tail stock	Quill diameter	mm (inch)	100 / 100 / 120 / 120 (3.9 / 3.9 / 4.7 / 4.7)		
	Quill bore taper (Live)		Live MT#5 **/Built-in MT#5***		
	Compressed air supply	mm (inch)	100 / 100 / 120 / 120 (3.9 / 3.9 / 4.7 / 4.7)		
Sub-spindle	Spindle speed (Belt [Built-in])	r/min	-		4000
	Spindle nose		-		A2-8
	Spindle bearing diameter (Front)	mm (inch)	-		130
	Spindle through hole diameter	mm (inch)	-		91
	Min. spindle indexing angle (C-axis)	deg	-		0.001
Motors	Main spindle motor	kW (Hp)	26/22/18.5 (34.9/30/25) (S6 25% / S6 60% / S1 Cont.)		26/22/18.5 (34.9/30/25) (XLYB/ULYB : 30/22)
	Sub spindle motor	kW (Hp)	-		30/26/22 (48.3/34.9/30) (S6 25% / 30min / S1 Cont.)
	Rotary tool spindle motor	kW (Hp)	7.5 / 5.5 (7 / 10)		
	Coolant pump motor	kW (Hp)	-		5.5 {7.5} (7 {10})
Power source	Electric power supply (Rated capacity)	kVA	42.04 / 42.04 / 42.83 / 42.83		44.83 / 44.83 / 45.61 / 45.61
Machine size	Machine height	mm (inch)	2020 / 2020 / 2315 / 2315 (79.5 / 79.5 / 91.1 / 91.1)		2315 (91.1)
	Machine dimension	length	mm (inch)	3910 / 4530 / 5615 / 6585 (153.9 / 178.3 / 221.1 / 259.3) (XLYB : 5857 (230.6), ULYB : 6827 (268.8))	
		width	mm (inch)	2002 / 2105 / 2280 / 2280 (78.8 / 82.9 / 89.8 / 89.8) (SY : 1978(77.9) / LSY : 2067(81.4))	
	Machine weight	kg (lb)	5850/ 7350 / 10150 / 11650 (12896.9 / 16203.7 / 22376.6 / 23683.5)		6000 / 7500 / 10300 / 11800 (13227.5 / 16534.4/ 22707.3 / 26014.4)
			6500 / 8000 / 10800 / 12300 (14329.8 / 17636.7 / 23809.6 / 27116.5) (SY : 7000(15432.1), LSY : 8500(18739.0), XLYB : 11000(24250.5), ULYB : 12500(27557.4))		

* The specifications and information above-mentioned may be changed without prior notice.

** : PUMA 3100/M/L/LM/Y/LY

*** : PUMA 3100XL/UL/XLM/ULM/XLY/ULY

* For more details, please contact DN Solutions.

{ } : Option

**Head Office**

19F, 10, Tongil-ro, Jung-gu, Seoul,
Republic of Korea, 04527

Tel: +82-2-6972-0370
Fax: +82-2-6972-0400

DN Solutions America

360 E State PKWY,
Schaumburg, IL. 60173,
United states

Tel: +1-315-265-7500

DN Solutions Europe

Emdener Strasse 24, D-41540
Dormagen, Germany

Tel: +49-2133-5067-100
Fax: +49-2133-5067-111

DN Solutions India

No.82, Jakkur Village
Yelahanka Hobli,
Bangalore-560064

Tel: +91-80-2205-6900
E-mail: india@dncompany.com

DN Solutions China

Room 101,201,301,
Building 39 Xinzhuan Highway
No.258 Songjiang District
China Shanghai (201612)

Tel: +86 21-5445-1155
Fax: +86 21-6405-1472

DN Solutions Vietnam

M.O.R.E building 2F, 40A-40B Ut
Tich Street, 04 Ward 04,
District Tan Binh District,
Ho Chi Minh City, Vietnam

Tel: +84 28-7304-0163

DN Solutions Mexico

Avenida Parque Bicentenario
#100 Nave M65L3-6,
Fraccionamiento San Isidro
Business Park,
Santa Rosa Jauregui,
Querétaro, México

E-mail: efrain.figueroa@dncompany.com

Sales inquiry

sales@dncompany.com